

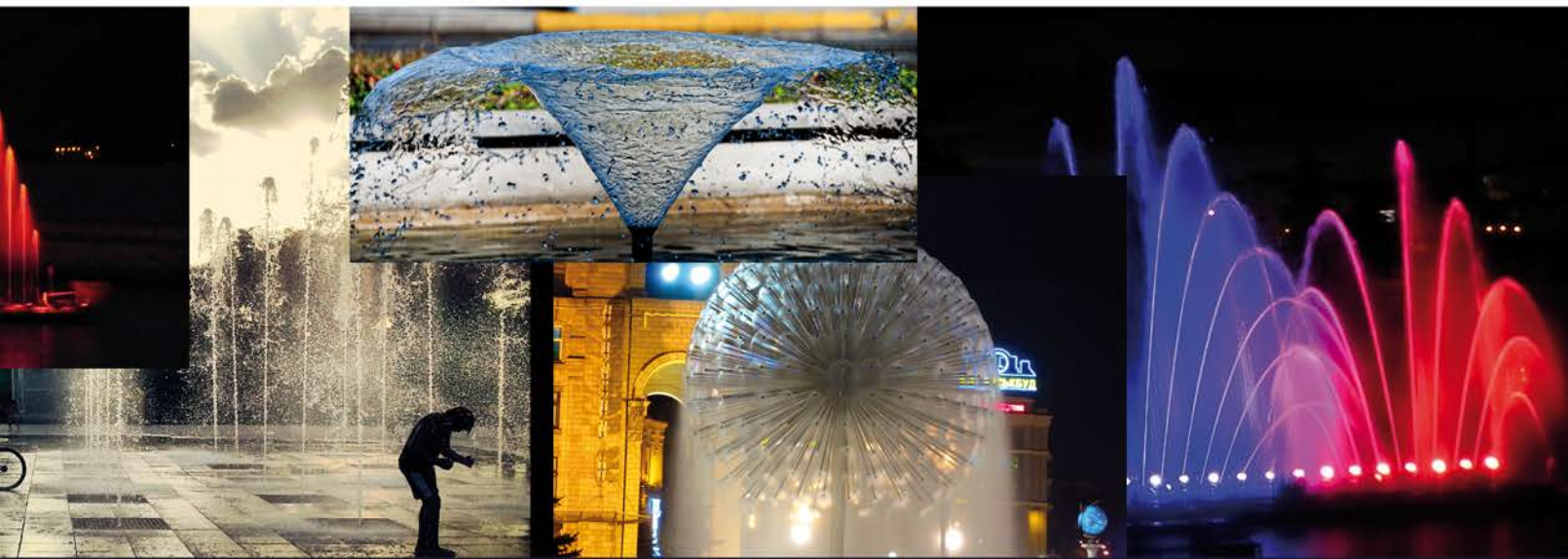

**SAFE-RAIN**

*Enjoy water rhythm!*



FOUNTAINS | FOUNTAINS EQUIPMENT | EQUIPAMIENTO PARA FUENTES | MATÉRIELS POUR FON

Junio 2020



Technical consulting



Developing water technologies



Product manufacturers



After-sales commitment

[www.saferain.com](http://www.saferain.com)

**Architectural fountains  
equipment/ Componentes  
para fuentes ornamentales**

# Enjoy water rhythm!

## ARCHITECTURAL FOUNTAINS EQUIPMENT MANUFACTURERS/ FABRICANTES DE MATERIAL PARA FUENTES ORNAMENTALES

**S**afe-Rain S. L. was founded in 1977 and dedicated its early years to manufacture irrigation equipment, shortly after, in 1982, started its activity in the architectural fountains area. Today, we **design, manufacture and market architectural fountains equipment, exporting our products to all 5 continents.**

We offer a **wide range of products and services**, adapted to a constantly evolving industry, our R + D + i is always open to new goals. Currently, we have 4.200m2 facilities, including factory, offices and a large testing area where we check the quality of our products.

Our premise is to adapt to your needs, and therefore, we do a **large range of bespoke developments** that can go

**S**afe-Rain S.L. fue fundada en 1977, y se dedicó en sus primeros años a la fabricación de material para riego, poco después, en 1982 comenzó su actividad en el sector de la fuentes ornamentales. Actualmente, nos dedicamos al **diseño, fabricación y comercialización de material para fuentes ornamentales, exportando nuestros productos a los 5 continentes.**

Disponemos de una **amplia gama de productos y servicios**, adaptándonos a un sector en constante evolución, nuestro departamento de I+D+i siempre está abierto a nuevas metas. Actualmente disponemos de unas instalaciones de 4.200m2 que incluyen fábrica, oficinas y una amplia zona de pruebas donde verificamos la calidad de nuestros productos.



Calle Cobre nº 6 - 45520. Villaluenga de la Sagra (Toledo) - SPAIN.

from simple adaptations of standard products, to a full product development. We want to connect, as closely as possible, with the needs of our customers and for that, we strongly emphasize the work of technical advice, **supporting our customers with our expertise to realize the projects and facilities where they compete**, a marketing help that certainly our customers worldwide, appreciate.

Nuestra premisa es adaptarnos a tus necesidades y por eso hacemos **gran variedad de desarrollos a medida** que pueden ir desde sencillas adaptaciones en productos standard hasta el desarrollo completo de un producto final. Queremos conectar, lo más estrechamente posible, con las necesidades de nuestros clientes y para ello hacemos mucho hincapié en el trabajo de asesoría técnica, **apoyando a nuestros clientes con nuestra experiencia para hacer realidad los proyectos e instalaciones por los que compiten**, una ayuda comercial que sin duda nuestros clientes en todo el mundo, valoran.

# INDEX/ INDICE

Fountain equipment/ Componentes de una fuente	Pag 4
Consulting and purchasing/ Consultoría y compra	Pag 5
Warranty and returns/ Garantía y devoluciones	Pag 6
Product consulting/ Asesoría de producto	Pag 7
R&D+i department/ Departamento I+D+i	Pag 7
Bespoke developments/ Desarrollos a medida	Pag 7
Partners program/ Programa Partners	Pag 8
Environment/ Medio ambiente	Pag 9
Security and certifications/ Seguridad y certificados	Pag 9
Catalogue usage/ Uso del catálogo	Pag 10
Ordering and shipping/ Pedidos y envíos	Pag 11
<b>WATER SHOW/ SHOW DE AGUA</b>	<b>Pag 12</b>
<b>DRY FOUNTAINS/ FUENTES SECAS</b>	<b>Pag 17</b>
<b>FLOATING FOUNTAINS/ FUENTES FLOTANTES</b>	<b>Pag 22</b>
<b>NOZZLES/ BOQUILLAS</b>	<b>Pag 30</b>
Crystalline jets/ Chorros cristalinos	Pag 31
Frothy jets/ Chorros espumosos	Pag 51
Rotatory nozzles/ Boquillas dinámicas	Pag 58
Spray features/ Chorros pulverizados	Pag 63
Spherical shapes/ Chorros esféricos	Pag 66
Bespoke nozzles/ Boquillas a medida	Pag 69
<b>LIGHTING/ ILUMINACIÓN</b>	<b>Pag 70</b>
<b>WATER CURTAINS/ CORTINAS DE AGUA</b>	<b>Pag 81</b>
<b>SPRAY RINGS/ COLECTORES</b>	<b>Pag 85</b>
<b>ACCESSORIES/ ACCESORIOS</b>	<b>Pag 90</b>
Hydraulic accessories/ Accesorios hidráulicos	Pag 91
Electrical accessories/ Accesorios eléctricos	Pag 97
Water pumps/ Bombas de agua	Pag 102
<b>BESPOKE FOUNTAIN KITS/ KITS DE FUENTE A MEDIDA</b>	<b>Pag 103</b>



**M**any of our customers are facing for the first time this type of facility, and others look for new ways to solve the technical requirements of their projects. The main issue is to **be spectacular, optimizing spending**. For this, we advise our customers and have all the necessary accessories to provide the available solutions.

Technical and environmental factors, make each project a challenge. That is why, **we offer you our team of specialist engineers** that will guide you throughout the whole process. Design, survey and construction. From the size of the basin and piping, to the prescription and sale of accessories: lighting, water pumps, valves, anemometers, level controllers, control panels...

**M**uchos de nuestros clientes se enfrentan por primera vez a una instalación de éste tipo, y otros buscan nuevas formas de resolver las necesidades técnicas de cada proyecto. La base fundamental es **ser espectaculares, optimizando el gasto**. Para eso asesoramos y disponemos de todos los accesorios necesarios para proveer a nuestros clientes de las soluciones disponibles.

Factores técnicos y ambientales, hacen de cada proyecto un reto. Para eso, **ponemos a vuestra disposición nuestro equipo de ingenieros especializados**, que os guiarán en todo el proceso. Diseño, estudio y construcción. Desde el tamaño del vaso y tuberías, hasta la prescripción y venta de accesorios: iluminación, bombas de agua, electroválvulas, anemómetros, controladores de nivel, paneles de control a medida...

## ARCHITECTURAL FOUNTAIN EQUIPMENT/ COMPONENTES DE UNA FUENTE ORNAMENTAL

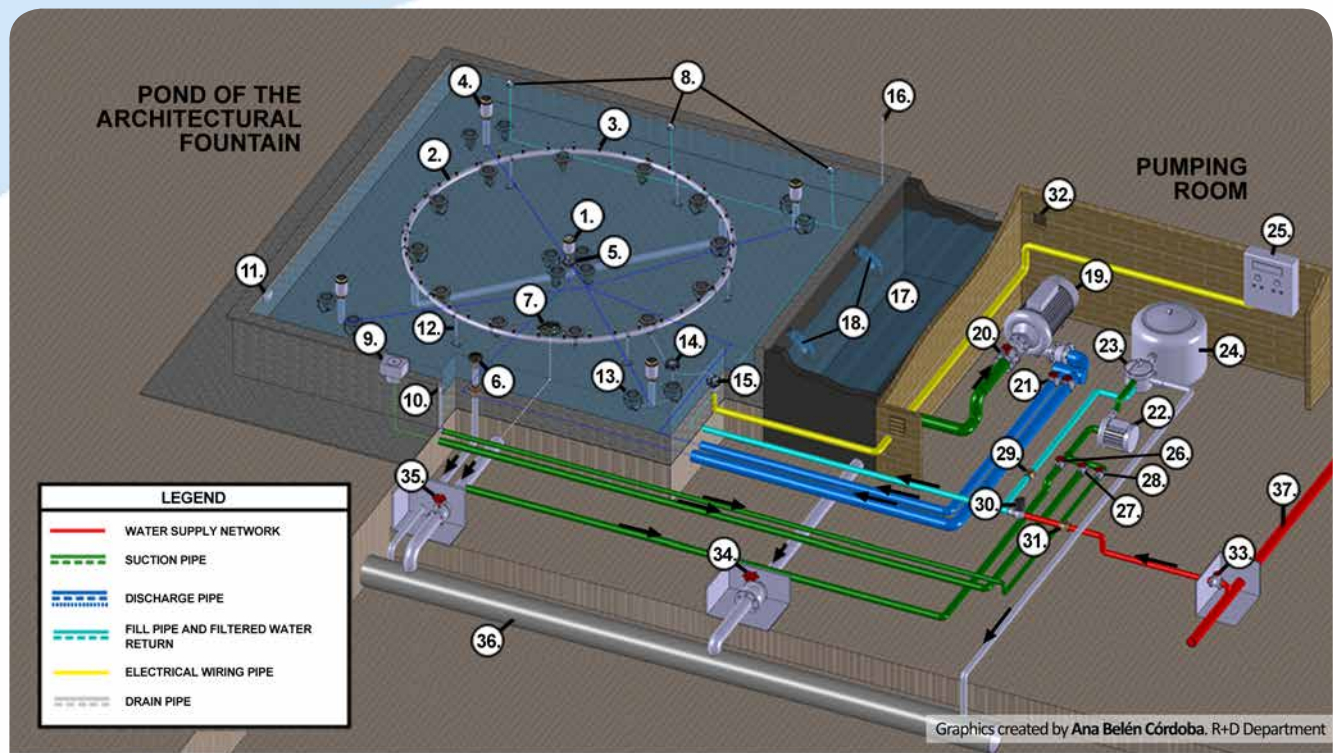

Graphics created by Ana Belén Córdoba. R+D Department



- 1. GEYSER NOZZLE
- 2. COLLECTOR RING
- 3. LANCE JET NOZZLES
- 4. FOAM JET TYPE NOZZLE
- 5. BALL TYPE ARTICULATED JOINT
- 6. OVERFLOW
- 7. BOTTOM WATER INTAKE

- 8. DIRECTIONAL AND FILLER NOZZLES
- 9. SKIMMER
- 10. SUCTION NOZZLE FOR CLEANING BASES
- 11. LEVEL SENSOR FOR REFILLING THE FOUNTAIN
- 12. COLLECTOR SUPPORT FEET
- 13. IP-68 UNDERWATER LIGHTS WITH LED BULBS
- 14. IP-68 UNDERWATER JUNCTION BOXES
- 15. IP-68 WALL BUSHING
- 16. ANEMOMETER
- 17. AUXILIARY TANK

- 18. WATER INLET OF THE AUXILIARY TANK
- 19. ELECTRIC PUMP
- 20. GATE VALVE
- 21. GATE VALVE
- 22. ELECTRIC PUMP
- 23. PURIFICATION UNIT SELECTION VALVE
- 24. SILEX SAND TANK
- 25. CONTROL PANEL FOR THE FOUNTAIN
- 26. BOTTOM OUTLET VALVE
- 27. SKIMMER VALVE

- 28. BOTTOM CLEANING VALVE
- 29. CHECK VALVE IN THE FILTERED WATER
- 30. ELECTRICALLY OPERATED VALVE
- 31. CHECK VALVE AT THE FILLING INLET
- 32. VENTILATION GRATES
- 33. SUPPLY VALVE
- 34. AUXILIARY TANK DRAINAGE VALVE
- 35. ARCHITECTURAL WATER FEATURE DRAINAGE VALVE
- 36. GENERAL WASTE WATER PIPES
- 37. PUBLIC SUPPLY NETWORK

# CONSULTING AND PURCHASING/ CONSULTORÍA Y COMPRA

**B**efore starting work on a project, we listen carefully to your requirements and needs, assisting you in everything you need. So, we can advise focused on the end result. Using our knowledge and experience to get an accurate result.

**A**ntes de empezar a trabajar en un proyecto escuchamos detenidamente tus ideas y objetivos. Así, podemos asesorarte poniendo el foco en el resultado final. Haciendo uso de todos nuestros materiales de apoyo, conocimientos y experiencia, para obtener un resultado estético y preciso.



## **Architectural fountain development**

The process of creating an architectural fountain is divided into three parts: **1) Fountain Design, 2) Technical Consulting, and 3) After Sales Service.**

## **Creación de una fuente ornamental**

El proceso de creación de una fuente ornamental se divide en tres partes: **1) Diseño, 2) Consultoría Técnica y 3) Servicio Post-venta.**



### 1) FOUNTAIN DESIGN

In many cases, we start from a conceptual idea and our work consists on advising you to **make it become a specific project**, giving examples of completed projects to help you design your own. Every architectural fountain is different, so we help you in the choice of the water displays and lighting most appropriate for your installation, until you have defined the final design.

### 2) TECHNICAL CONSULTING

Once you have a clear concept of the aesthetics of your architectural fountain, **we offer the technical expertise of our engineers**. We help you solving important questions, like:

- **Studying the construction of the architectural fountain**, we assist you in such relevant matters as the choice of the water pump most suited to the needs of your project.
- **Pipe sizing** (hydraulic calculations).
- Advice on something as simple as the **electrical installation of the architectural fountain**.
- **Choice of the lighting system** (LED or halogen) most suited to your project.
- **Estudiando la obra civil de la fuente ornamental**, asesoramos en puntos tan relevantes como la elección de la bomba de agua que mejor se adecúa a las necesidades de tu proyecto.
- **Dimensionamiento de tuberías** (cálculos hidráulicos).
- Asesoramiento en algo tan sensible como **la instalación eléctrica de la fuente ornamental**.
- **Elección del sistema de iluminación** (LED o halógeno) más adecuado para tu proyecto.

### 3) AFTER SALES SERVICE

We stick with you throughout the project to **meet your needs until it is completed**. We monitor the development of your project to assist you in everything that you need, and if any problems arise with one of our products, we will be ready to resolve it as quickly as possible. If, for any reason, a product fails due to a manufacturing defect, we will replace it for you, no questions asked.



### 1) DISEÑO DE LA FUENTE

En muchas ocasiones partimos de una idea conceptual y nuestro trabajo consiste en asesorarte para **convertir esa idea en un proyecto concreto**, ofreciéndote ejemplos e ideas de proyectos ya realizados para desarrollar el tuyo propio. Cada fuente ornamental es diferente, por este motivo te ayudamos en la elección de los juegos de agua e iluminación más adecuados para tu instalación, hasta tener el diseño final definido.

### 2) CONSULTORÍA TÉCNICA

Una vez tenemos claro el aspecto final de la fuente ornamental, **nuestros ingenieros expertos pasan a asesorarte técnicamente**. Ayudándote a resolver temas tan importantes como:

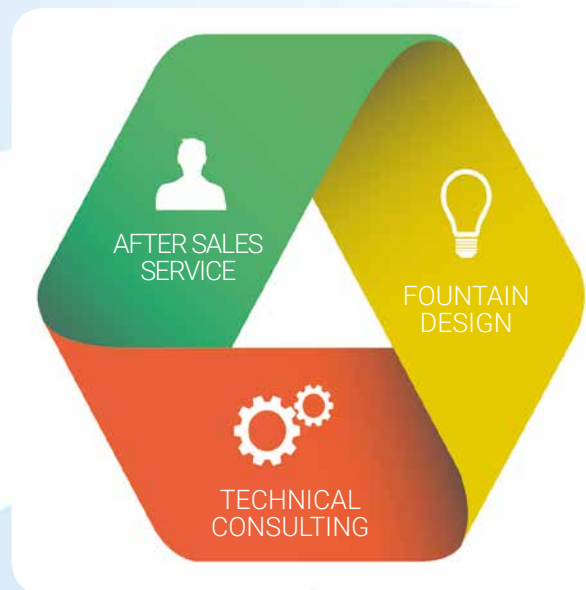

### 3) SERVICIO POSTVENTA

Nos encargamos de **atender todas tus necesidades hasta que el proyecto esté finalizado**. Seguimos el desarrollo de tu proyecto para asesorarte en todo aquello que necesites y si surgiese cualquier problema con una de nuestros productos, estaremos atentos para solucionarlo tan pronto como sea posible.

## WARRANTIES AND REFUNDS

All products manufactured by SAFE-RAIN S.L. carry a **2 YEARS GUARANTEE**, which is valid from the customer purchase date against any manufacturing defects. Any products not manufactured by SAFE-RAIN, S.L. fall under the guarantee offered by the relevant manufacturer.

## GARANTÍAS Y DEVOLUCIONES

Todos los productos fabricados por SAFE RAIN, S.L. tienen **2 AÑOS DE GARANTÍA** contra todo defecto de fabricación a partir de la fecha de compra de nuestro cliente. En el caso de los productos no fabricados por SAFE RAIN, S.L. la garantía es la ofrecida por el fabricante.



## R&D+i DEPARTMENT

**O**ur R & D + i policy is clear, and is based on two principles. **"If our market demands it, we must have it, and contributing as much as possible to the industry development"**. For all this to be truly effective, we start from real needs of many projects that we face every day, where you are who challenge us, the reason of being for this department.

## DEPARTAMENTO DE I+D+i

**N**uestra política de I+D+i es clara, y se fundamenta en dos principios. **"Si nuestro mercado lo demanda, tenemos que tenerlo, y contribuir en la medida de lo posible a la evolución del sector"**. Para que todo esto sea realmente efectivo, partimos de necesidades reales de multitud de proyectos a los que nos enfrentamos a diario, dónde sois vosotros los que nos planteáis los retos, la razón de ser de éste departamento.

## PRODUCT ADVICE/ ASESORÍA DE PRODUCTO

**I**n addition, we offer a free consulting service on our products. **Mainly focused on the new products** that we market each year, so that everyone is aware of the new possibilities that are emerging at both design and technical. Your projects are shaping the innovations of the future, so, we assume that a close communication benefits all parties.

**A**demás, ofrecemos un servicio de asesoría gratuita sobre nuestros productos. **Principalmente orientado a las novedades** que vamos sacando al mercado año tras año, para que todos estemos al corriente de las nuevas posibilidades que van surgiendo, tanto a nivel de diseño, como técnico. Son vuestros proyectos los que van perfilando las novedades del futuro, por lo que una comunicación estrecha entendemos que beneficia a todas las partes.

## BESPOKE DEVELOPMENTS

**O**ur premise is to adapt to your needs, and, thus, we do many developments for fountains that can range from simple adaptations of standard products, to the complete development of a new final product. **Being manufacturers and having broad experience in the industry gives us the ability to be able to develop and manufacture the product most suited to your needs.**

## DESARROLLOS A MEDIDA

**N**uestra premisa es adaptarnos a tus necesidades y por eso hacemos gran variedad de desarrollos a medida que pueden ir desde sencillas adaptaciones en productos standard hasta el desarrollo completo de un producto final. **El hecho de ser fabricantes y tener una gran experiencia en el sector nos da la capacidad de poder desarrollar y fabricar el producto que más se ajuste a tus requerimientos.**

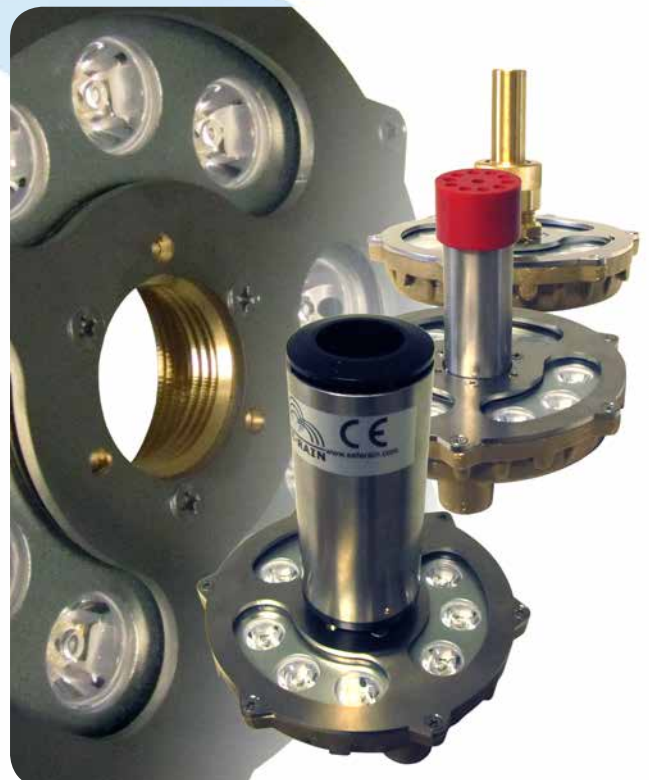



# PARTNERS PROGRAM/ PROGRAMA DE PARTNERS

**W**e are currently **undergoing a process of commercial expansion** and we would like to expand our worldwide partners network. Therefore, we would like to offer different companies in the sector the chance to sell our products for Architectural Water Features in their respective areas.

**A**ctualmente **estamos en un proceso de expansión comercial** y deseamos aumentar nuestra red de partners a nivel mundial, por lo que ofrecemos la posibilidad a distintas empresas del sector, de poder representarnos en sus respectivas áreas.



**In Safe-Rain we are convinced that, if our partners do business, we do too.**

**En Safe-Rain tenemos muy claro que, si nuestros partners hacen negocio, nosotros también.**

## What advantages do we offer?

We empower the business development of our partners

- Training and technical advice.
- Better conditions and rates.
- Transfer of business contacts.
- Certificate of authorized partner and entitled to use the partner logo.
- Access to exclusive materials through the "Partners Area" on the web. (CAD Files, advertising materials...)
- Publishing success stories.
- Collaboration in promotional activities.
- Joint development of 3D animations for major projects.

## Partners commitment

- Minimum annual business volume.
- Joint business plan. Coordinate to multiply the chances of success.
- Provide documentation on major projects.
- Representing the brand Safe-Rain in the online and offline channels.

## ¿Qué ventajas ofrecemos?

Potenciamos la creación de negocio de nuestros partners

- Formación y asesoramiento técnico.
- Mejores condiciones y tarifas.
- Cesión de contactos comerciales.
- Certificado de partner autorizado y derecho al uso del logotipo de partner.
- Acceso a documentación exclusiva a través de la "zona de partners" de la web (Archivos CAD, materiales de marketing...).
- Publicación de casos de éxito.
- Colaboración en acciones promocionales.
- Desarrollo conjunto de animaciones 3D para grandes proyectos.

## Compromiso de nuestros Partners

- Volumen de negocio mínimo anual.
- Plan de negocio conjunto. Coordinarse para multiplicar las opciones de éxito.
- Aportar documentación sobre grandes proyectos.
- Representar la marca Safe-Rain, en los canales online y offline.

## CERTIFICATES AND POLICY/ CERTIFICADOS Y POLÍTICA

All our products pass a **rigorous quality control** that follows the guidelines of **ISO 9001 certificate**. Once they have passed the quality control, we proceed to package and ship the materials. By guaranteeing our customers the proper functioning of all our products, we assume a commitment for the entire production process.

Todos nuestros fabricados pasan un **exigente control de calidad** que sigue las directrices del **certificado ISO 9001**. Toda vez que pasen este control de calidad, se procede al embalaje y envío del material. Al garantizar a nuestros clientes, el buen funcionamiento de todos nuestros productos, asumimos un compromiso del que nos hacemos responsables durante todo el proceso de producción.



## ENVIRONMENT/ MEDIO AMBIENTE

Safe-Rain is making a **clear commitment to sustainability** by promoting proper use of water and energy consumption. Often together with considerable savings in the facilities maintenance. This factor, sustainability, has become in recent years a key development factor of our new products, and we have made significant efforts to control our entire production process.

Safe-Rain está haciendo una **apuesta clara por la sostenibilidad**, promoviendo un uso adecuado del agua y el consumo energético. Muchas veces acompañado de un ahorro notable en el mantenimiento de las instalaciones. Éste factor, la sostenibilidad, se ha convertido en los últimos años en un factor clave para el desarrollo de nuestros nuevos productos, y hemos hecho un esfuerzo notable en el control de todo nuestro proceso de producción.

## SAFETY

Being mostly public facilities, safety is a determining factor. It is important to end up with a showy installation, but, that can be enjoyed by all the people in a safety way, is a priority. In Safe-Rain we fulfill stricter public safety laws.

## SEGURIDAD

Al tratarse de instalaciones mayormente públicas, la seguridad es un factor determinante. Que una instalación sea llamativa es importante, pero que puedan disfrutarla con seguridad grandes y pequeños es prioritario. En Safe-Rain cumplimos las legislaciones de seguridad pública más estrictas.







# How to order ?/ ¿Cómo hacer pedidos?

Safe-Rain requires orders to be written to the email address [orders@saferain.com](mailto:orders@saferain.com) or through its sales department.

- Additional cost for freight and packing.
- Unless previously agreed terms, orders must be paid by bank transfer before shipping.
- The customer is responsible for paying state and/or local taxes.
- For further details please contact our sales department +34 925 531 480 or by mail to the address [orders@saferain.com](mailto:orders@saferain.com).

*If we do not manufacture the product you need, Safe-Rain can purchase the, exact or equivalent, products you need for your project.*

Safe-Rain requiere que sus pedidos se hagan por escrito a la dirección [orders@saferain.com](mailto:orders@saferain.com) o a través de su departamento comercial.

- Costo adicional por servicios de carga y embalaje.
- Salvo condiciones previamente acordadas, los pedidos deberán abonarse por transferencia bancaria antes de su envío.
- El cliente es responsable del pago de los impuestos estatales y/o locales.
- Para más detalles, por favor, diríjense a nuestro departamento de ventas +34 925 531 480 o por correo a la dirección [orders@saferain.com](mailto:orders@saferain.com).

*Si nosotros no fabricamos el producto que necesita, Safe-Rain puede adquirir los productos, exactos o equivalentes, que necesita para su proyecto.*

## Shipping

We ship products **worldwide**. Offering our customers the possibility of tracking your product at all times.

We will use the freight company and the service that best suits the weight and volume of shipping, and delivery time. Sea, air, door to door, groupage... (DHL, Fedex or UPS).



## Envíos

Enviamos productos a **todo el mundo**. Ofreciendo a nuestros clientes la tranquilidad de poder hacer un seguimiento de su producto en todo momento.

Usaremos la compañía de transporte y el servicio que mejor se adecúe al peso y volumen del envío, y su plazo de entrega. Marítimo, aéreo, puerta a puerta, grupajes... (DHL, Fedex o UPS).

### Incoterms/

- **DAP.** Delivered at place/ Puerta a puerta.
- **CIF.** Cost, insurance and freight/ Coste seguro y flete.
- **EXW.** Ex works.
- **CFR.** Cost and freight/ Coste y flete.

## Warranties and refunds/ Garantías y devoluciones

All products manufactured by SAFE-RAIN S.L. carry a **2 YEARS GUARANTEE**, which is valid from the customer purchase date against any manufacturing defects. Any products not manufactured by SAFE-RAIN, S.L. fall under the guarantee offered by the relevant manufacturer.

Todos los productos fabricados por SAFE RAIN, S.L. tienen **2 AÑOS DE GARANTÍA** contra todo defecto de fabricación a partir de la fecha de compra de nuestro cliente. En el caso de los productos no fabricados por SAFE RAIN, S.L. la garantía es la ofrecida por el fabricante.



# WATER SHOW/ ESPECTÁCULOS ACUÁTICOS

Dancing fountain/ Fuentes danzantes	Pag 13
Digital curtain/ Cortina digital	Pag 14
3D Fountain animation/ Animación 3D de fuentes	Pag 16

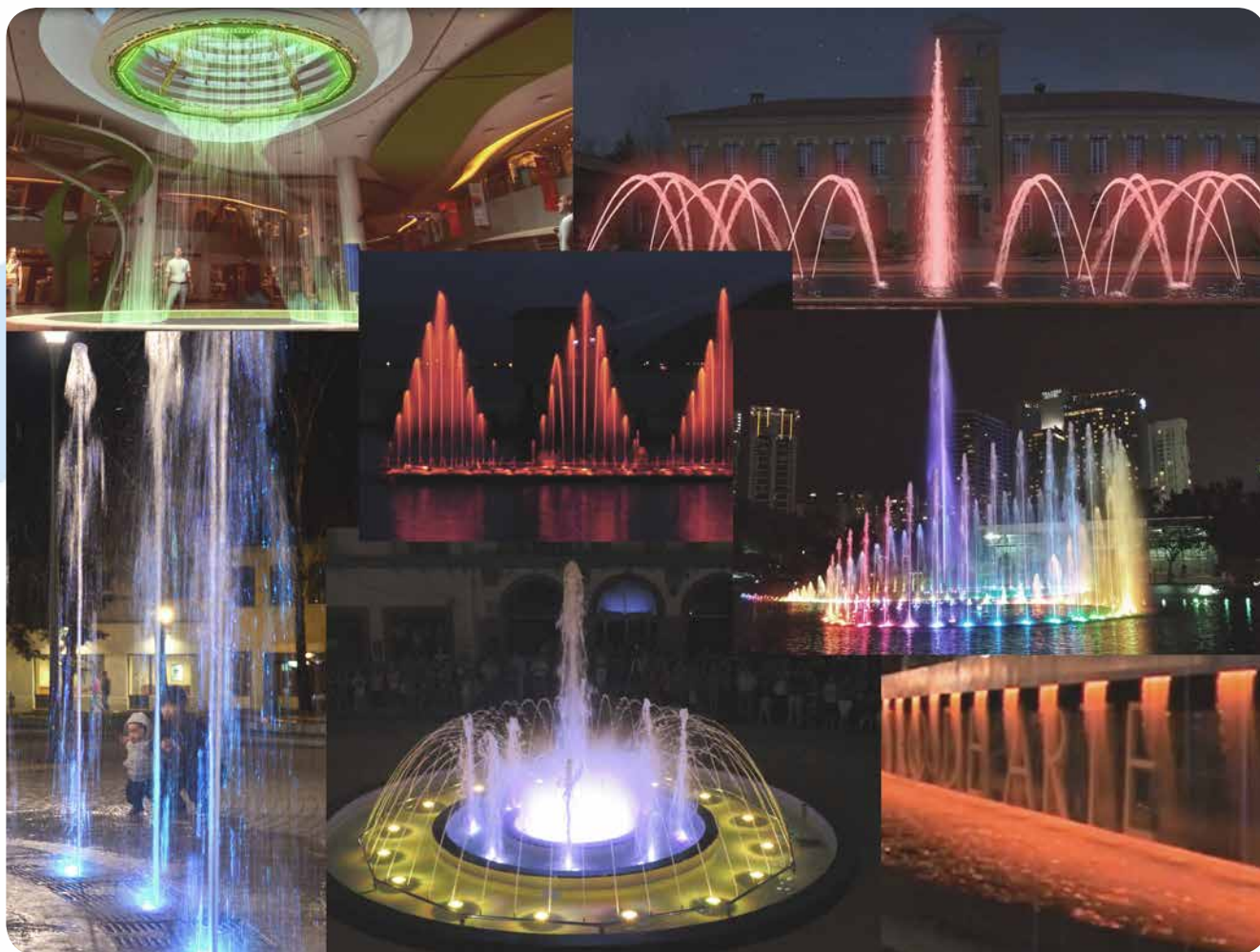

**G**et an impressive water show thanks to the products you will find in this section. They combine water, light, sound and technology to provide the viewer a water entertainment show that will never leave anybody unmoved.

Starting with the dancing fountains where water dances to the music beat, thanks to PLC or DMX technologies incorporated in our Control Panels, and ending with digital water curtains that thanks to its different geometrical shapes can print all sorts of symbols. All these products are specifically designed by Safe-Rain and incorporate the latest water entertainment technologies to empower your water show.

**C**onsigue realizar un impresionante show de agua gracias a los productos que encontrarás en esta sección. Todos ellos conjugan agua, luz, sonido y tecnología para ofrecer al espectador un espectáculo acuático que no dejará a nadie indiferente.

Desde las fuentes danzantes donde el agua baila al ritmo de la música gracias a las tecnologías PLC o DMX que componen nuestros Paneles de Control, hasta la cortina de agua digital que en sus diferentes formas geométricas imprimen todo tipo de símbolos. Todos estos productos son expresamente diseñados por Safe-Rain e incorporan la última tecnología para estar a la altura de tu proyecto de show de agua.

# Dancing Fountains/ Fuentes Danzantes

**G**et spectacular water effects into your **musical or dancing fountains** thanks to our **DMX or PLC technology control panels**. Our **DMX control panels** integrate a PC, software and the DMX technology needed to make the water dance to the beat of the music. For those projects where dynamism in the water is required but there is no music, we recommend using our **PLC technology control panels**.

**C**onsigue **espectaculares efectos acuáticos en tus fuentes musicales o danzarinas** gracias a nuestros paneles de control de **tecnología DMX o PLC**. Nuestros **paneles de control DMX** integran un PC, el software y la tecnología DMX necesaria para que puedas hacer bailar el agua al compás de la música. Para aquellos proyectos donde se requiera dinamismo en el agua pero sin música te recomendamos el uso de nuestros **paneles de control con tecnología PLC**.

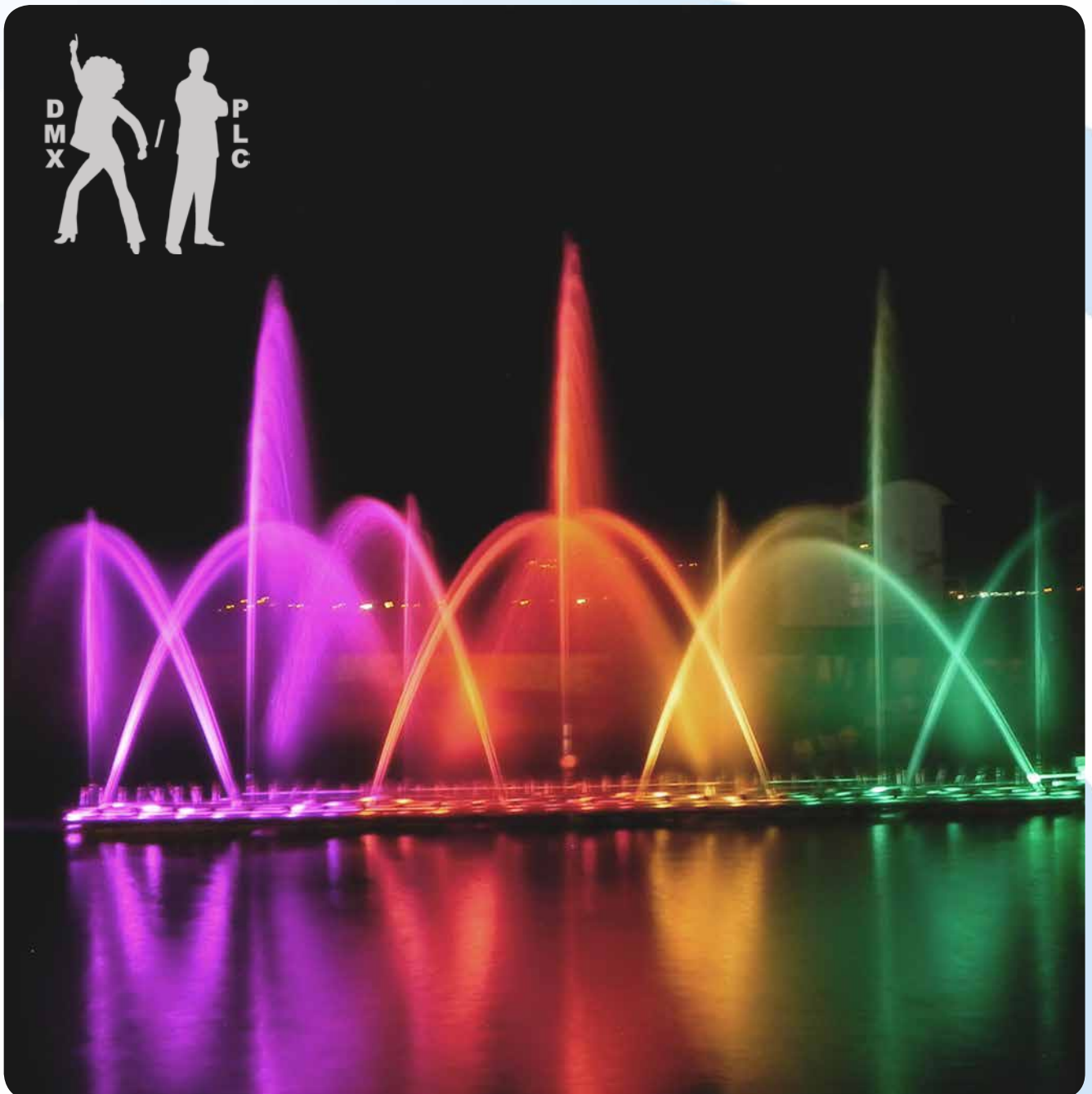

Further information at [www.saferain.com](http://www.saferain.com) | Más información en [www.saferain.com](http://www.saferain.com)



# DMX Control panels/ Cuadros de control DMX

The musical fountain show **make water dance to the beat of the music** and are currently one of the most demanded shows around the world. This type of **water entertainment technologies are based on the DMX technology integrated into the Control Panel that rules the whole show**. These control panels are designed by Safe-Rain expressly for the needs of your dancing fountain, and contain a **touchscreen PC, DMX software and electronics** to make water dance to the beat of the music.

Las fuentes musicales **hacen bailar el agua al ritmo de la música** y actualmente son uno de los espectáculos más demandados en todo el mundo. Este tipo de **fuentes musicales están basadas en la tecnología DMX que integrada en el Cuadro de Control gobierna todo el espectáculo acuático**. Estos paneles de control están diseñados por Safe-Rain expresamente para las necesidades de tu fuente danzarina y contienen un **PC con pantalla táctil, el software y la electrónica DMX** necesaria para hacer bailar el agua al compás de la música.

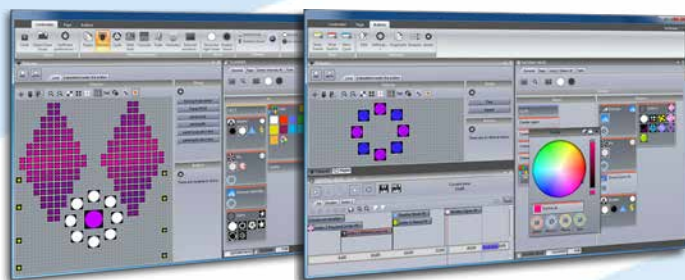

- They include **computer technology and DMX** necessary to be able to install a **musical fountain**.
- **Software** allows you to program dancing water. **Set the synchronization between water displays, lighting and musical choreography**.
- If desired, the **Control Panel can be delivered programmed** and ready to run the aquatic choreography you've defined in your **dancing fountain**.
- For any project your **show can be modified** (water features, light and music) **as many times as desired**, in a simple and intuitive way.
- There is the option of **programming remotely** through an internet secure connection.
- This water entertainment technology allows communication between the software and the equipment, by a single cable, **greatly reducing the wiring inside the basin of the dancing fountain**.
- **Control of all the elements of the musical fountain**, either individually or in sets, thanks to the DMX protocol.
- Incluyen la **tecnología informática y DMX** necesaria para que puedas instalar **fuentes danzantes**.
- Gracias al **software** puedes definir la **sincronización entre los juegos de agua, la iluminación y la coreografía musical**.
- Si lo deseas, el **Panel de Control se puede entregar programado** y preparado para ejecutar la coreografía acuática que hayas definido en tu **fuelle musical**.
- Para cualquier proyecto **se puede modificar el show de agua** (juegos de agua, luz y música), **tantas veces como se desee**, de una manera muy sencilla e intuitiva.
- Posibilidad de **programación en remoto** habilitando una conexión a internet segura.
- Permite la comunicación entre el software y los equipos a controlar mediante un solo cable, **reduciendo mucho el cableado dentro del vaso de las fuentes danzantes**.
- **Control de todos los elementos de la fuente musical**, bien de manera individual o en conjuntos, gracias al protocolo DMX.

# PLC Control panels/ Cuadros de control PLC

**W**hen we talk about **interactive fountain that do not include music**, usually the best option is to use **PLC (Programmable Logic Controller) technology Control Panels with except of large projects where we recommend the DMX technology that is easily configurable.**

**C**uando hablamos de **fuentes bailarinas que no incluyen música**, normalmente la mejor opción es usar **Paneles de Control con tecnología PLC (Controlador Lógico Programable) salvo en proyectos de gran tamaño donde recomendamos la tecnología DMX porque es fácilmente configurable.**



**BESPOKE  
A MEDIDA**

## TECHNICAL FEATURES/ ESPECIFICACIONES TÉCNICAS.

- Recommended for **dancing water fountain projects with low or medium complexity that do not incorporate musical choreography.**
- **The Control Panel is delivered programmed** with the water displays that you've defined in your dancing fountain.
- Incorporates PLC technology, with **maximum reliability and stability of operation.**
- **Simplicity of the Panel wiring.**
- **Cheaper than DMX technology** for not too complex fountain projects.
- You can change the programming of the water displays thanks to the PLC software.
- Recomendado para proyectos de **fuentes danzantes de complejidad baja o media que no incorporen coreografía musical.**
- **El Panel de Control se entrega programado** con los juegos de agua que hayas definido en tu fuente musical.
- Incorpora tecnología PLC, de **máxima fiabilidad y estabilidad de funcionamiento.**
- **Simplicidad del cableado** del cuadro.
- Precio **más económico que la tecnología DMX** para fuentes danzarinas no muy complejas.
- Se puede modificar la programación de los juegos de agua gracias al software del autómatas.



**VISIT OUR BLOG/ VISITA NUESTRO BLOG**

- How to make a dancing fountain
- Cómo hacer una fuente danzante



# 3D Fountain animation/ Animación 3D de fuentes

## Is there a better way to sell a dancing fountain, that watching it running before installing it?

In SafeRain we believe that it doesn't, that is why we offer this exclusive service for our Customers and Partners worldwide. We just need you to provide us all the relevant information about your project and we'll do the whole 3d fountain animation.

## ¿Hay mejor modo de vender una fuente danzante que verla funcionando antes de instalarla?

En SafeRain creemos que no, y por eso ofrecemos este exclusivo servicio para nuestros Clientes y Partners de todo el mundo. Tan sólo necesitamos que nos proporciones toda la información relevante sobre tu proyecto y nosotros nos encargaremos de hacer la animación de tu fuente de agua 3D.



## WHAT DO WE NEED TO MAKE A FOUNTAIN ANIMATION?/ ¿ QUÉ NECESITAMOS PARA ANIMAR UNA FUENTE EN 3D?

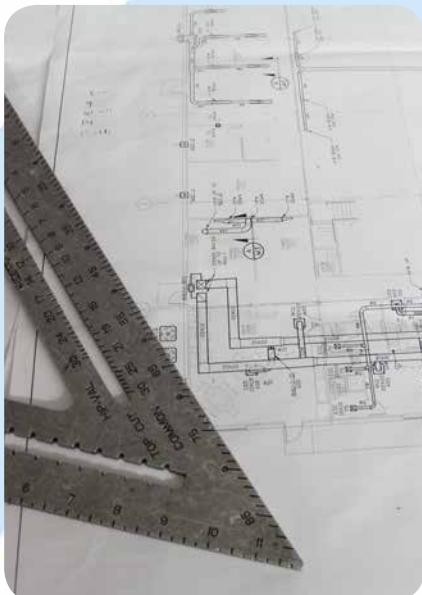

- Shape and dimensions of the architectural fountain basin.
- Number of nozzles, type, location, orientation and dimensions of the jets.
- Number of solenoids and frequency converters, also their location.
- Optionally, photos of the environment where the architectural fountain will be placed.
- For a musical fountain project, we will need the song for the 3D fountain animation, and should never exceed 2 mins.
- Forma y dimensiones del vaso de la fuente.
- Número de boquillas, tipo, disposición, orientación y dimensiones de los chorros de agua.
- Número de electroválvulas y variadores de frecuencias así como su disposición.
- Opcionalmente fotos del entorno donde ira la fuente.
- En el caso de las fuentes musicales necesitaremos la canción necesaria para la animación. Y nunca superara los 2 mins. Así aseguramos la sincronización de tu proyecto de fuente de agua 3d.

# DRY DECK FOUNTAINS/ FUENTES SECAS

Waterboy/ Waterboy Pag 19

Waterboy PLUS/ Waterboy PLUS Pag 20

Dry fountains/  
Fuentes secas



**T**he Waterboy dry fountain kits are **easy to install** and **adapt to a wide range of designs for this type of installation**. They are found in public squares and shopping centers, since they provide playful water displays in a minimum of space, while the dry fountain is running, yet allow for a dry walking environment when the fountain is turned off.

The Waterboy is a kit made of stainless steel and **especialmente diseñado para instalarse en el pavimento y resistir el vandalismo**, since its grid is durable and shock-resistant, protecting the kit.

**L**os kits de fuentes secas Waterboy son de **fácil instalación** y **se adaptan a la gran diversidad de diseños que hay para este tipo de instalaciones**. Podemos encontrarlos tanto en plazas públicas como en centros comerciales ya que permiten que en un mismo espacio podamos disfrutar de los juegos de agua, mientras la fuente seca funciona, y de un entorno transitable cuando la fuente está pagada.

Los Waterboy son un kit fabricado en acero inoxidable y **especialmente diseñado para instalarse en el pavimento y resistir el vandalismo** ya que su chapa es resistente a los golpes y protege todo el compacto.



# DRY DECK FOUNTAIN EQUIPMENT/ COMPONENTES DE UNA FUENTE SECA

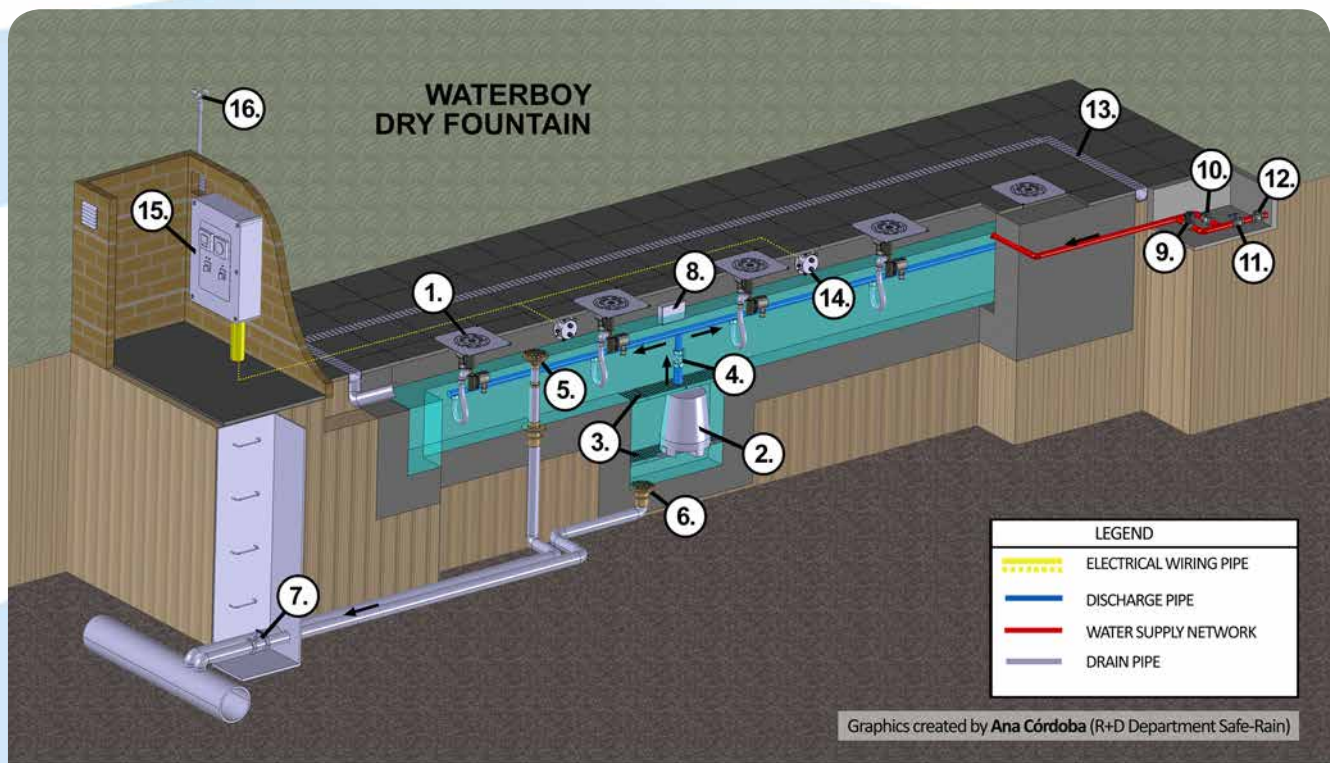

- |             |               |                 |                               |             |                |                             |                            |                         |                          |                  |  |                               |                  |  |                |
|-------------|---------------|-----------------|-------------------------------|-------------|----------------|-----------------------------|----------------------------|-------------------------|--------------------------|------------------|--|-------------------------------|------------------|--|----------------|
| 1. WATERBOY | 2. WATER PUMP | 3. GRID OR MESH | 4. PUMP FLOW REGULATION VALVE | 5. OVERFLOW | 6. BASE OUTLET | 7. DRY FOUNTAIN DRAIN VALVE | 8. LEVEL PROBE FOR FILLING | 9. SOLENOID FOR FILLING | 10. MANUAL FILLING VALVE | 11. SUPPLY VALVE | 12. RETENTION VALVE IN THE FILLING INLET | 13. PERIMETER CANAL WITH GRID | 14. IP68 BUSHING | 15. ELECTRICAL PANEL FOR THE WATERBOY AND PUMP | 16. ANEMOMETER |
|-------------|---------------|-----------------|-------------------------------|-------------|----------------|-----------------------------|----------------------------|-------------------------|--------------------------|------------------|--|-------------------------------|------------------|--|----------------|

**D**ry deck fountains are distinguished by having a hidden structure beneath our feet, which means that we can have an architectural fountain in the same space as a dry environment, when the fountain is not running. For this, we use a concrete conduit, a structure that contains the water for the proper operation of the architectural fountain. This water returns to the tank through a perimetral grid placed around it, and through the dry fountain kit, which includes a grid for returning and draining water to the tank. You must use a filtering and purification system for water maintenance.

**L**as fuentes secas y visitables se caracterizan por tener una estructura escondida bajo nuestros pies, lo cual implica que podamos disponer en el mismo espacio de una fuente ornamental con sus respectivos juegos de agua y de un entorno seco, cuando la fuente está apagada. Para ello utilizamos un canal corrido de hormigón, estructura que a su vez contiene el agua para el correcto funcionamiento de la fuente ornamental. Este agua retorna al vaso mediante una rejilla perimetral ubicada alrededor de la misma y también a través del kit de fuente seca que incorpora una rejilla para el retorno y drenaje de ésta al vaso. Para el mantenimiento del agua, es indispensable utilizar sistemas de filtrado y depuración.



## LED SEA Ring/ Corona LED SEA

ALSI 304

LED

RGB

DMX

- LED RGB and White, 27W power (12-24V DC), Lens angle 10° and 30°, DMX Controllable
- LED RGB y Blanco, 27W de potencia (12-24V DC), Angulo de lente de 10° y 30°, Controlable DMX

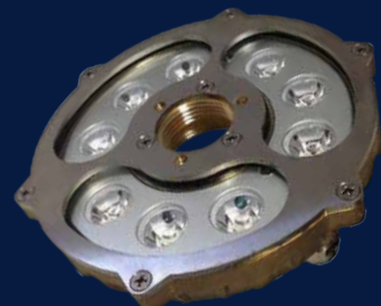

# Waterboy

A complete interactive fountain that is expressly designed for installations where children and adults can enjoy themselves among spectacular water changes, creating an atmosphere full of life.

- A complete **easy-to-install interactive fountain set**.
- It **includes a nozzle**.
- We fit **three LED (White/ RGB) spotlights** lighting.
- Energy savings of 85% with LED technology.
- We fit a secondary underwater electric valve in addition to the main one in order to maintain constant pressure at all times.
- As an **option**, you can fit an **control panel to program the different interactive water features**.
- Exclusive Safe-Rain design.

Completo juego de agua interactivo expresamente diseñado para instalaciones donde niños y adultos puedan divertirse entre espectaculares cambios acuáticos que indudablemente llenarán de vida el espacio que ocupan.

- **Conjunto de fuente seca y de fácil instalación.**
- **Incluye una boquilla.**
- Incorporamos **tres focos sumergibles LED (Blanco/RGB)**.
- Ahorro energético del 85% por la tecnología LED.
- Incorporamos una segunda electroválvula sumergible complementaria a la principal para mantener la presión constante en todo momento.
- **Opcionalmente**, puede incorporar un **cuadro eléctrico para programar los diferentes juegos de agua**.
- Diseño exclusivo de Safe-Rain.

Dry fountains/  
Fuentes secas



**AISI 304** **LED** **RGB**

Dimensions/ Dimensiones

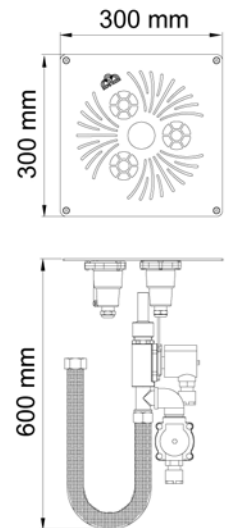

Optional/ Opcional



Round upper plate/  
Chapa superior Redonda.  
Add "R" letter at the end of  
the reference/ Añadir una  
"R" al final de la referencia.

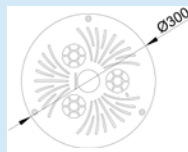

White LED/ LED Blanco	F420119	F4202111	F4209118			
RGB LED/ LED RGB	F4201121	F4202122	F4209129			
Without lights/ Sin foco	F4201132	F4202133	F4209131			
Nozzle/ Tobera	Lance jet/ Chorro Lanza G 1"	Lance jet/ Chorro Lanza G 1"	Crown of jets/ Corona chorros G 3/4"			
Water outlet/ Salida agua (mm)	Ø12	Ø16	12 + 6 + 1			
Connection/ Conexión	G 1" F/H					
Material/ Material	Stainless steel - Brass/ Acero inoxidable - Latón					
Weight/ Peso (kg)	10					
Height/ Altura (m)	Q	P	Q	P	Q	P
	l/min	m.c.a	l/min	m.c.a	l/min	m.c.a
0,5	30	4,9	35	4,3	22	4,1
1,0	37	5,3	54	5,2	34	4,6
1,5	44	5,9	70	6,1	40	5,2
2,0	50	6,5	80	7,1	47,5	5,7



# Waterboy PLUS

Dry fountains/  
Fuentes secas

**D**ry fountain kit made of stainless steel and specifically designed by Safe-Rain to be installed in pavement. It includes an **LED lighting system Controllable RGB** or white, which creates attractive water and light displays for the viewer that are easily programmable and installable.

**K**it de fuente seca fabricado en acero inoxidable y expresamente diseñado por Safe-Rain para instalarse en el pavimento. Incorpora un sistema de **iluminación LED RGB controlable o blanca**, que permite mostrar al espectador atractivos juegos de agua y luz fácilmente programables e instalables.



**Brass/ Latón    Stainless steel/ Acero inoxidable**

**AISI 304    LED    RGB    DMX    PWM**

Dimensions/ Dimensiones								Performance/ Rendimiento						
Product name/ Denominación	Reference/ Referencia	LED	Nozzle/ Tobera	Outlet/ Salida	Adjust. Angle/ Angulo ajuste	Connection/ Conexión	Weight/ Peso (kg)	Height/ Altura (m)	0,5	1,0	1,5	2,0	2,5	3,0
Waterboy PLUS	F4214226	RGB	Multijet/ Multichorro	Equivalent/ Equivalente Ø12	5°	1" M BSP/ NPT	4,5	Q l/min	26	38	47	54	59	64
	F4224227	White/ Blanca						P m.c.a	0,9	1,8	2,5	3,5	4,3	5,2
	F4213225	RGB	Snowy jet/ Chorro de nieve	Ø24	-	1/2" M BSP/ NPT	4,5	Q l/min	68	92	112	125		
	F4223226	White/ Blanca						P m.c.a	3	5,5	8,1	10,8		
Waterboy PLUS + 2 Solenoid valves/ 2 Electroválvulas	F4214327	RGB	Multijet/ Multichorro	Equivalent/ Equivalente Ø12	5°	1" F/H BSP/ NPT	8,5	Q l/min	26	38	47	54	59	64
	F4224328	White/ Blanca						P m.c.a	1,6	3,7	5,2	6,8	8,4	10
	F4213326	RGB	Snowy jet/ Chorro de nieve	Ø24	-	1" F/H BSP/ NPT	8,5	Q l/min	68	92	112	125		
	F4223327	White/ Blanca						P m.c.a	4	7,4	10,8	14,1		
Waterboy PLUS +Under water pump/ Bomba sumergible	50Hz	F4214428	RGB	Multijet/ Multichorro	Equivalent/ Equivalente Ø12	5°	-	11	Height/ Altura (m)	Max 2,5				
		F4224429	White/ Blanca											
	60Hz	F4214529	RGB											
		F4224521	White/ Blanca							Max 3,0				

## Electrical data/ datos eléctricos

LED Lighting/ Iluminación LED			Solenoid Valves/ Electroválvulas		Waterpump/ Electrobomba	
LED	Power/ Potencia	Voltage/ Tensión	Power/ Potencia	Voltage/ Tensión	Power/ Potencia	Voltage/ Tensión
RGB	17W	12/24V DC	20W	24V DC	220W	240V AC/ 50Hz
White/ Blanca	21W				250W	120V AC/ 60Hz

## Optional/ Opcional



Round upper plate/ Chapa superior Redonda.  
Add "R" letter at the end of the reference/  
Añadir una "R" al final de la referencia.

## Dimensions/ Dimensiones

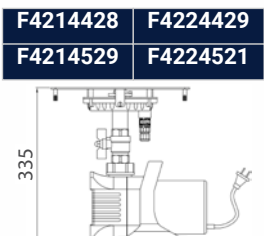
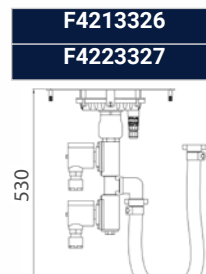
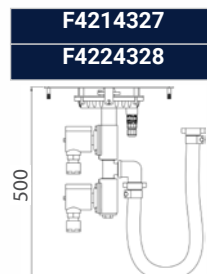
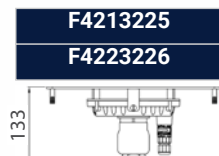
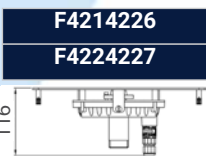
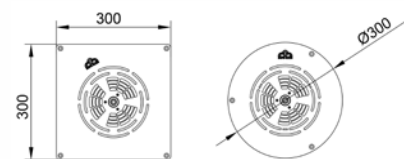

# Control Software/ Software de Control

The control of dry deck fountains is now possible thanks to the development of a new software that allows **full control of the PLC** (Programmable Logic Controller) without the need of having prior computer skills. Thanks to a **7" touch screen**, the configuration of the dry fountain is as simple as adjusting all electronic parameters required so that the water features act as desired.

El control para fuentes secas y pisables es ahora posible gracias al desarrollo de un nuevo software que permite el **gobierno total del autómatas o PLC** sin necesidad de que el cliente cuente con conocimientos informáticos previos. Gracias a una **pantalla táctil de 7"**, la configuración de la fuente de piso seco es tan simple como ajustar todos los parámetros electrónicos necesarios de forma que los juegos de agua actúen según lo deseado.

Dry fountains/  
Fuentes secas



## PRODUCT FEATURES/ CARACTERÍSTICAS DEL PRODUCTO

- Schedule a **maximum of 8 turning on and off daily**, both hydraulics and electrical.
- Define a **maximum of 10 sets or sequences of operation** of the dry fountain jets. It is also possible to associate the water features scheduled for different days of the week so that each day, chosen sets are performed automatically.
- Adjust the values of the variable speed drives to **define the height of the jets**. It is possible to define the transition time of the previous value of speed to the current (rampa).
- Define the water jets height based on wind speed (decreasing it if they are equipped with a frequency converter or turning them off).
- Verify individually the proper operation of each element connected to the panel in the installation phase.
- Programar **un máximo de 8 encendidos y apagados diarios**, tanto de la parte hidráulica como de la eléctrica.
- Definir **un máximo de 10 juegos o secuencias de funcionamiento** de los chorros de la fuente seca. Además, es posible asociar los juegos programados a los diferentes días de la semana de manera que cada día actúen automáticamente los juegos elegidos.
- Ajustar los valores de los variadores de velocidad para **definir la altura de los chorros**. Es posible, definir el tiempo de transición del valor anterior de velocidad al actual (rampa).
- Definir la altura de los chorros teniendo en cuenta la velocidad del viento (disminuyéndola si están dotados de variador de frecuencia o apagándolos).
- Verificar de manera individual el buen funcionamiento de cada elemento conectado al cuadro, en la fase de instalación.



# FLOATING FOUNTAINS AND AERATORS/ FUENTES FLOTANTES Y AIREADORES

Safe-Rain series/ Serie Safe-Rain Pag 23

Safe-Rain aerators/ Aireadores Safe-Rain Pag 27

Domestic fountain/ Fuente doméstica Pag 28

Select and Titan series/ Series Select y Titán Pag 29

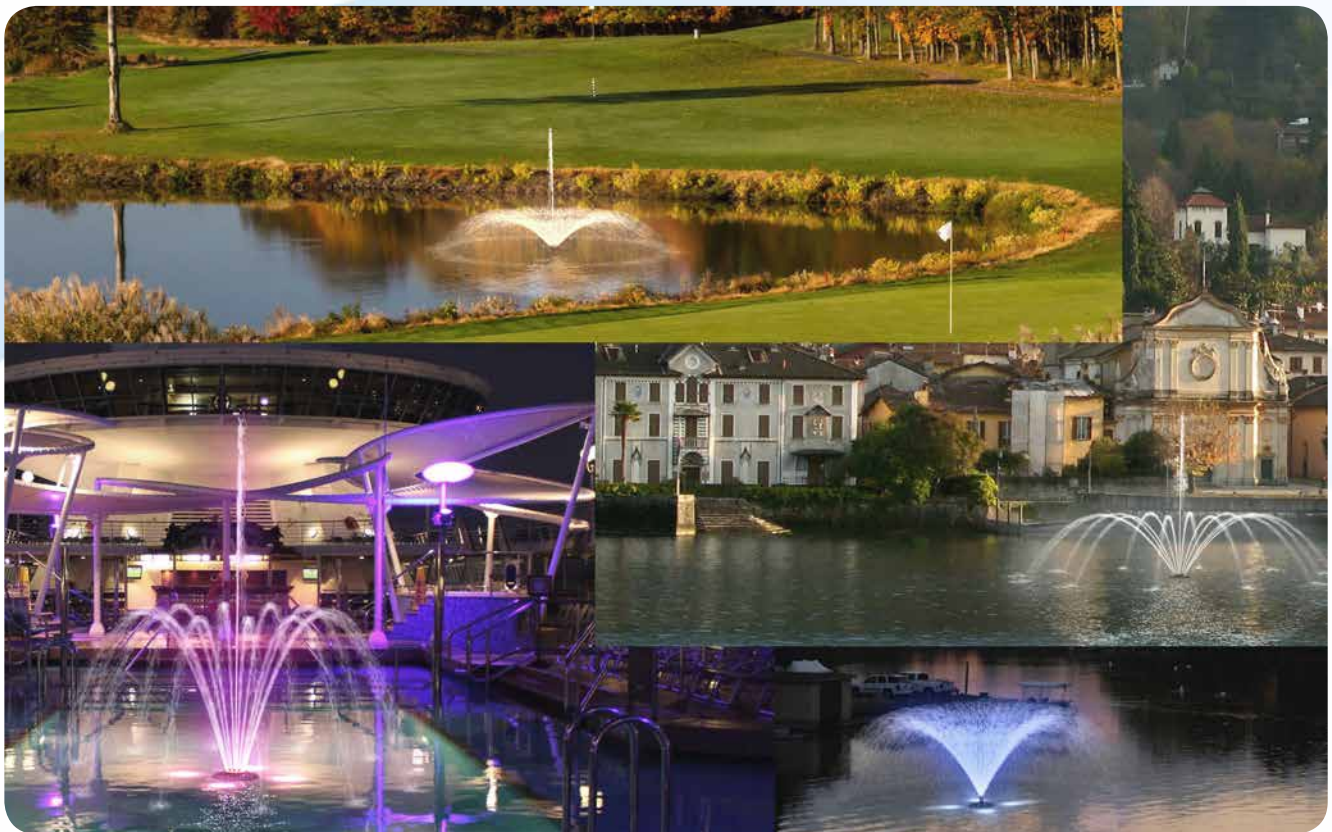

**F**loating fountains and aerators are fountain kits that can be easily installed in lakes or ponds, both artificial and natural. Safe-Rain sells a wide variety of models ranging from 1/2 hp. to 40 hp. providing its own range of manufactured products, and Titan, Select, and Evolution series by Aqua Control.

In addition to its impressive effect on water, it is used for **artificial lakes aeration**. Without sufficient circulation, a pond becomes stratified with warmer water on the surface and colder, oxygen-depleted water on the bottom. Lack of oxygen increases the anaerobic (without oxygen) decomposition of the sludge at the bottom. This decomposition helps to develop nutrients in the pond, which, in turn, increases algae blooms.

**L**as fuentes y aireadores flotantes se caracterizan por tratarse de kits de fácil instalación, que se utilizan habitualmente en estanques y lagos tanto artificiales como naturales. Safe-Rain comercializa, una amplia variedad de modelos que oscilan entre 1/2 CV. y 40 CV. disponiendo de su propia gama de fabricados y de las series Titan, Evolution y Select de Aqua Control.

Además de su impresionante efecto en el agua sirven para la **aireación de lagos artificiales**. Sin suficiente circulación, el estanque se estratifica, con agua más caliente en la superficie, y más fría y con menos oxígeno en el fondo. La falta de oxígeno en el fondo facilita la descomposición del lodo, favoreciendo la aparición de algas y mal olor.



# Safe-Rain series/ Serie Safe-Rain

**S**afe-Rain floating fountains have been specifically designed for **decorating swimming pools, ponds and lakes** providing a perfect complement to decorate these architectural landscapes. Easy to install, these kits incorporate a pump between **0.75 hp. - 1.34 hp.** and with the addition of different nozzles can achieve different water features.

**L**as fuentes flotantes de SafeRain han sido expresamente diseñadas para la **decoración de piscinas, estanques y lagos** aportando un complemento idóneo para la decoración de estos paisajes arquitectónicos. Fácilmente instalables, estos kits incorporan una bomba de entre **0,75 hp. - 1,34 hp.** y gracias a la incorporación de diferentes boquillas podemos conseguir diferentes juegos de agua.



Floating f./  
F. flotantes



## PRODUCT FEATURES/ CARACTERÍSTICAS DEL PRODUCTO



- **Easy to install.** These kits incorporate everything needed for proper operation.
- As easy as **plug and play**, and starts up.
- Depending on the model is provided with a **vertical pump with 0.75 hp. or horizontal with 1.34 hp.**
- Only **one person is needed to complete installation.**
- They can be installed in **pools and ponds with a minimum depth of 60 cm.**
- **Optionally**, can be provided with 2-4-6-8 PAR-56 lights or 2-4-6-8 LED RGB Lake lights.
- **Optionally**, we provide the protection and control panel.
- **Fácilmente instalable.** Estos kits incorporan todo lo necesario para su correcto funcionamiento.
- Fácil instalación, **basta con enchufar** y funciona.
- Según modelo se proporciona con **bomba vertical de 0,75 hp. u horizontal de 1,34 hp.**
- Se requiere sólo **una persona para completar la instalación.**
- Se pueden instalar en **piscinas y estanques con una profundidad mínima de 60 cm.**
- **Opcionalmente**, lo proporcionamos con 2-4-6-8 focos PAR-56 o con 2-4-6-8 Focos Lake RGB.
- **Opcionalmente**, proporcionamos el cuadro de control y protección.

# Safe-Rain series floating fountains/ Fuentes flotantes serie Safe-Rain

VOLGA/ VOLGA										
Refer- ence/ Referencia	Pump/ Electrobomba			Control panel/ Cuadro eléctrico	Performance/ Rendimiento				Aeration mod- ule/ Módulo de aireación	
	Motor		Voltage		Height A	Diameter	Flow			
	W	hp					V/ Hz	l.p.m		m³/h
F4500009	560	0,75	230/ 50	F6357104	3,00	5,00	330	19,8	✓	
F4501203			120/ 60							F6357205
F4502002	1000	1,34	230/ 50	F6357104	4,25	6,00	390	23,4		✓
F4503003			120/ 60							



CALIX/ CÁLIZ										
Reference/ Referencia	Pump/ Electrobomba			Control panel/ Cuadro eléctrico	Performance/ Rendimiento				Aeration mod- ule/ Módulo de aireación	
	Motor		Voltage		Height A	Diameter	Flow			
	W	hp					V/ Hz	l.p.m		m³/h
F4500011	560	0,75	230/ 50	F6357104	1,50	6,00	430	25,8	✓	
F4501012			120/ 60							F6357205
F4502013	1000	1,34	230/ 50	F6357104	2,00	7,50	540	32,4		✓
F4503014			120/ 60							

ARUM LILY/ CALA										
Reference/ Referencia	Pump/ Electrobomba			Control panel/ Cuadro eléctrico	Performance/ Rendimiento				Aeration mod- ule/ Módulo de aireación	
	Motor		Voltage		Height A	Height B	Diameter	Flow		
	W	hp								V/ Hz
F4502024	1000	1,34	230/ 50	F6357104	2,50	0,75	5,00	661	39,7	✓
F4503025			120/ 60							



DANUBE/ DANUBIO											
Reference/ Referencia	Pump/ Electrobomba			Control panel/ Cuadro eléctrico	Performance/ Rendimiento				Aeration mod- ule/ Módulo de aireación		
	Motor		Voltage		Height A	Height B	Diameter	Flow			
	W	hp								V/ Hz	l.p.m
F4500033	560	0,75	230/ 50	F6357104	2,75	1,50	3,00	260	15,6	✓	
F4501034			120/ 60								F6357205
F4502035	1000	1,34	230/ 50	F6357104	4,75	2,25	4,60	313	18,8		✓
F4503036			120/ 60								

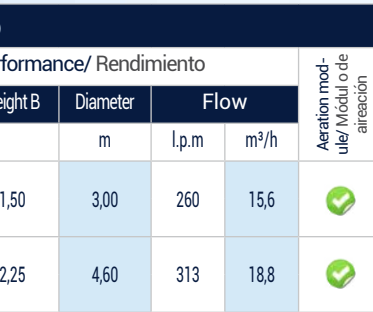

MISSISSIPI/ MISISIPI											
Reference/ Referencia	Pump/ Electrobomba			Control panel/ Cuadro eléctrico	Performance/ Rendimiento				Aeration mod- ule/ Módulo de aireación		
	Motor		Voltage		Height A	Height B	Diameter	Flow			
	W	hp								V/ Hz	l.p.m
F4500044	560	0,75	230/ 50	F6357104	2,50	1,00	5,20	315	18,9	✓	
F4501045			120/ 60								F6357205
F4502046	1000	1,34	230/ 50	F6357104	3,75	1,50	6,40	404	24,2		✓
F4503047			120/ 60								



PALM TREE/ PALMERA										
Reference/ Referencia	Pump/ Electrobomba			Control panel/ Cuadro eléctrico	Performance/ Rendimiento				Aeration mod- ule/ Módulo de aireación	
	Motor		Voltage		Height A	Diameter	Flow			
	W	hp					V/ Hz	l.p.m		m³/h
F4500055	560	0,75	230/ 50	F6357104	2,50	3,60	285	17,1	✓	
F4501056			120/ 60							F6357205
F4502057	1000	1,34	230/ 50	F6357104	3,50	5,00	400	24		✓
F4503058			120/ 60							



DANCING/ DANCING										
Reference/ Referencia	Pump/ Electroboomba			Control panel/ Cuadro eléctrico	Performance/ Rendimiento					Aeration module/ Módulo de aireación
	Motor		Voltage		Height A	Height B	Diameter	Flow		
	W	hp	V/ Hz		m		m	l.p.m	m³/h	
F4500066	560	0,75	230/ 50	F6357104	2,50	2,30	3,50	100	6,0	✔
F4501067			120/ 60	F6357205						
F4502068	1000	1,34	230/ 50	F6357104	5,00	3,50	6,60	140	8,4	✔
F4503069			120/ 60	F6357205						



THAMES/ TÁMESIS											
Reference/ Referencia	Pump/ Electroboomba			Control panel/ Cuadro eléctrico	Performance/ Rendimiento					Aeration module/ Módulo de aireación	
	Motor		Voltage		Height A	Height B	Height C	Diameter	Flow		
	W	hp	V/ Hz		m			m	l.p.m		m³/h
F4500077	560	0,75	230/ 50	F6357104	2,75	1,50	0,75	3,40	278	16,7	✔
F4501078			120/ 60	F6357205							
F4502079	1000	1,34	230/ 50	F6357104	4,00	2,00	1,00	5,40	329	19,7	✔
F4503071			120/ 60	F6357205							



SEINE/ SENA										
Reference/ Referencia	Pump/ Electroboomba			Control panel/ Cuadro eléctrico	Performance/ Rendimiento					Aeration module/ Módulo de aireación
	Motor		Voltage		Height A	Height B	Diameter	Flow		
	W	hp	V/ Hz		m		m	l.p.m	m³/h	
F4500088	560	0,75	230/ 50	F6357104	3,25	1,25	5,20	227	13,6	✔
F4501089			120/ 60	F6357205						
F4502081	1000	1,34	230/ 50	F6357104	4,50	1,75	8,40	269	16,1	✔
F4503082			120/ 60	F6357205						



LANCE JET/ LANZA										
Reference/ Referencia	Pump/ Electroboomba			Control panel/ Cuadro eléctrico	Performance/ Rendimiento					Aeration module/ Módulo de aireación
	Motor		Voltage		Height A	Diameter	Flow			
	W	hp	V/ Hz		m	m	l.p.m	m³/h		
F4500099	560	0,75	230/ 50	F6357104	3,50	1,00	264	15,8	✔	
F4501091			120/ 60	F6357205						
F4502092	1000	1,34	230/ 50	F6357104	4,75	1,30	300	18,0	✔	
F4503093			120/ 60	F6357205						



EUPHRATES/ EUFRATES										
Reference/ Referencia	Pump/ Electroboomba			Control panel/ Cuadro eléctrico	Performance/ Rendimiento				Aeration module/ Módulo de aireación	
	Motor		Voltage		Height A	Diameter	Flow			
	W	hp	V/ Hz		m	m	l.p.m	m³/h		
F4500101	560	0,75	230/ 50	F6357104	0,50	1,60	560	33,6	✔	
F4501102			120/ 60	F6357205						



WILLOW/ SAUCE										
Reference/ Referencia	Pump/ Electroboomba			Control panel/ Cuadro eléctrico	Performance/ Rendimiento					Aeration module/ Módulo de aireación
	Motor		Voltage		Height A	Diameter	Flow			
	W	hp	V/ Hz		m	m	l.p.m	m³/h		
F4500112	560	0,75	230/ 50	F6357104	2,50	3,30	275	16,5	✔	
F4501113			120/ 60	F6357205						
F4502114	1000	1,34	230/ 50	F6357104	3,50	4,00	325	19,0	✔	
F4503115			120/ 60	F6357205						





Vertical pump  
560 W. 0,75 hp.

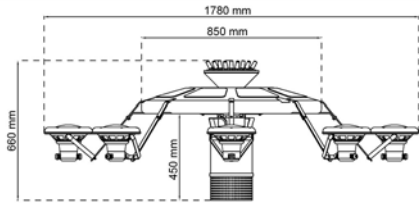

Horizontal pump  
1000 W. 1,34 hp.

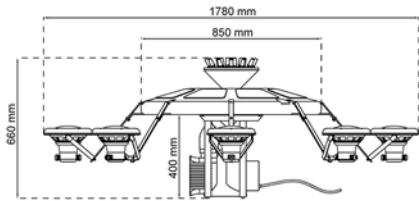

Heights references:  
A, B, C

Diameter:  
D

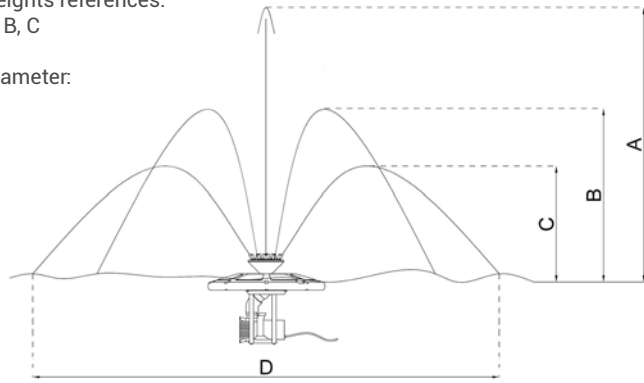

**FLOATING FOUNTAINS LIGHTING/ ILUMINACIÓN DE FUENTES FLOTANTES**

Lighting/ Iluminación	Voltage V/ Hz	Control panel/ Cuadro eléctrico	Lights type/ Tipo de focos	PAR 56 Lights number/ Nº de focos	LAKE Lights number/ Nº de focos	VOLGA	CALIX	ARUM LILY	DANUBE	MISSISSIPI	PALM TREE	DANCING	THAMES	SEINE	LANCE JET	EUPHRATES	WILLOW	
LED	230/ 50	F6357115	RGB	8	-	✓	✓	✓	✓	✓	✓	✓	✓	✓	✓		✓	
				4	-	✓	✓	✓	✓	✓	✓	✓	✓	✓	✓	✓	✓	
			White	8	-	✓	✓	✓	✓	✓	✓	✓	✓	✓	✓	✓	✓	✓
				4	-	✓	✓	✓	✓	✓	✓	✓	✓	✓	✓	✓	✓	✓
	120/ 60	F6357216	RGB	8	-	✓	✓	✓	✓	✓	✓	✓	✓	✓	✓	✓	✓	✓
				4	-	✓	✓	✓	✓	✓	✓	✓	✓	✓	✓	✓	✓	
			White	8	-	✓	✓	✓	✓	✓	✓	✓	✓	✓	✓	✓	✓	✓
				4	-	✓	✓	✓	✓	✓	✓	✓	✓	✓	✓	✓	✓	✓
	230/ 50	F6357148	RGB	-	8	✓	✓	✓	✓	✓	✓	✓	✓	✓	✓	✓	✓	✓
		F6357159	White	-	8	✓	✓	✓	✓	✓	✓	✓	✓	✓	✓	✓	✓	✓
120/ 60	F6357240	RGB	-	8	✓	✓	✓	✓	✓	✓	✓	✓	✓	✓	✓	✓	✓	
	F6357251	White	-	8	✓	✓	✓	✓	✓	✓	✓	✓	✓	✓	✓	✓	✓	
Incandescent	230/ 50	F6357135		4	-	✓			✓	✓							✓	
				2	-		✓	✓								✓	✓	
	120/ 60	✗																



Optimal/ Óptimo



Recommended/ Aconsejable



Not available/ No disponible

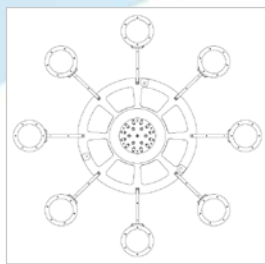
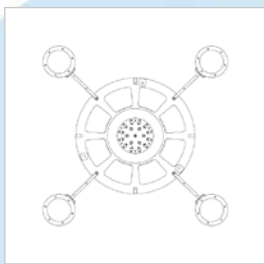
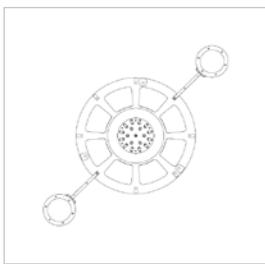

\* Floating fountain with aeration max 6 spotlights/ Fuente flotante con aireación máximo 6 focos.

F4501001 Spotlights support for Safe-Rains floating fountains/ Soporte para focos de Fuente Flotante Safe-Rain

**CONTROL PANEL/ PANEL DE CONTROL**



Safe-Rains floating fountains Control Panel/ Panel de Control de Fuentes Flotantes Safe-Rain

# Safe-Rain aerators and aeration modules/ Aireadores y módulos de aireación Safe-Rain

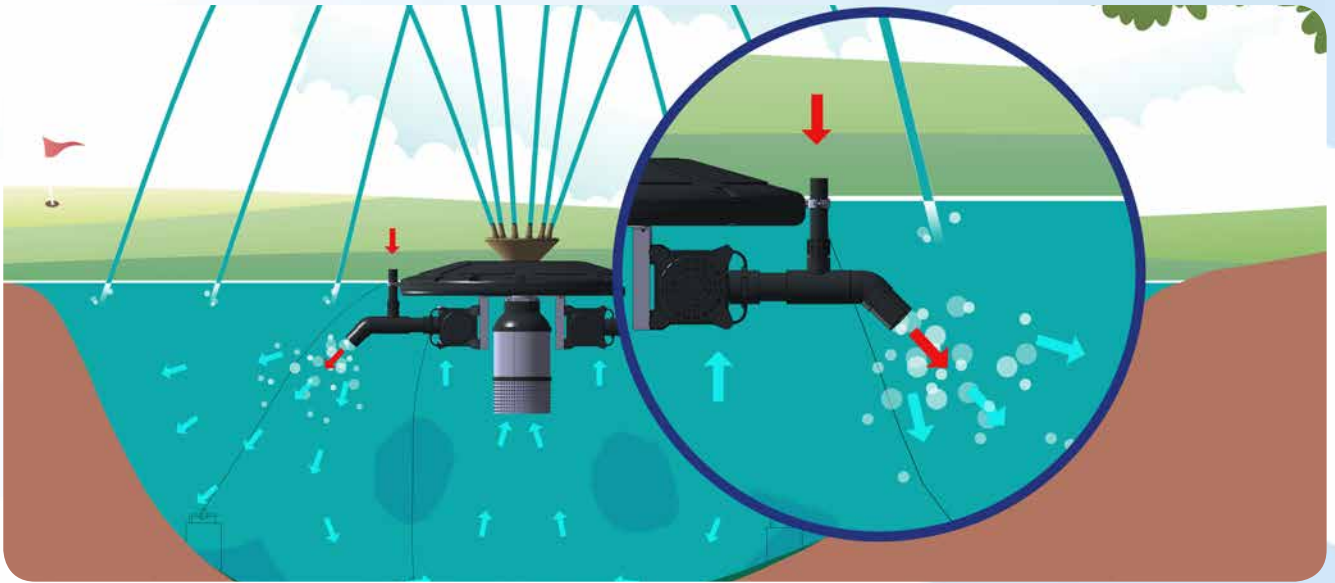

Floating f./  
F. flotantes

**T**hanks to **water pond aeration system** manufactured by Safe-Rain you could oxygenate the water of any lake, facilitating biological cycles and ensuring the effectiveness of bacterial products that reduce nutrients and clarify water.

**G**racias a los **aireadores para estanques artificiales** fabricados por Safe-Rain conseguirás oxigenar el agua de cualquier lago facilitando los ciclos biológicos y asegurando la eficacia de productos bacterianos reductores de nutrientes y de aclarado del agua.

SUBMERGED AERATOR/ AIREADOR SUMERGIDO								
Reference/ Referencia	Pumps number/ Número de bombas	Pump/ Electrobomba		Air flow/ Caudal aire		O <sub>2</sub> Flow/ Caudal O <sub>2</sub>		
		Motor	Voltage	l/h	m <sup>3</sup> /h	l/h	m <sup>3</sup> /h	
		W	V/ Hz					
F4612408	2	130	230/ 50	10800	10,8	2268	2,3	
F4612509	2	220	230/ 50	12000	12,0	2520	2,5	
F4612803	2	220	120/ 60	12000	12,0	2520	2,5	
F4612601	2	420	230/ 50	14760	14,8	3096	3,1	
F4612702	2	420	120/ 60	14760	14,8	3096	3,1	
F4610801	1	500	230/ 50	10000	10	2100	2,1	
F4610902	1	500	120/ 60	10000	10	2100	2,1	



The submersible pond aerator is designed to meet the need of those who want to **oxygenate the water of a pond without the water jets** included in a floating fountain.

El aireador sumergido está concebido para satisfacer la necesidad de todos aquellos que quieran **oxigenar el agua de un estanque sin incluir los chorros de agua** de una fuente flotante.



\* Safe-Rain floating fountains accessory module.

SUBMERGED AERATOR MODULE/ MÓDULO AIREADOR SUMERGIDO								
Reference/ Referencia	Pumps number/ Número de bombas	Pump/ Electrobomba		Air flow/ Caudal aire		O <sub>2</sub> Flow/ Caudal O <sub>2</sub>		
		Motor	Voltage	l/h	m <sup>3</sup> /h	l/h	m <sup>3</sup> /h	
		W	V/ Hz					
F4622409	2	2 x 130	230/ 50	10800	10,8	2268	2,3	
F4622501	2	2 x 220	230/ 50	12000	12,0	2520	2,5	
F4622804	2	2 x 220	120/ 60	12000	12,0	2520	2,5	
F4622602	2	2 x 420	230/ 50	14760	14,8	3096	3,1	
F4622703	2	2 x 420	120/ 60	14760	14,8	3096	3,1	
F4620802	1	500	230/ 50	17500	10	3675	3,7	
F4620903	1	500	120/ 60	17500	10	3675	3,7	

\* Módulo accesorio para fuentes flotantes serie Safe-Rain.



# Pools floating fountain/ Fuente doméstica

**P**ool floating fountain is a set of water jets, nozzle crown with ring of 48 LED fountain lights and submersible pump. It is ideal for its simplicity and size, to install in ponds and swimming pools.

**C**onjunto de fuente flotante, boquilla corona, con corona de 48 LED y bomba de agua sumergible. Por su tamaño y sencillez, son ideales para su uso en estanques o piscinas.

Floating f. /  
F. flotantes



## PRODUCT FEATURES/ CARACTERÍSTICAS DEL PRODUCTO

- Size of the Set: Ø 350mm x 190mm (h), cable length 10 mts.
- Height of jets: 1.016mm x Ø 762mm wide, adjustable height through the water pump.
- Brilliant Led lights, with auto-changing colour in red, green, blue and different possibilities, it does not need controller.
- Easy assembly and installation, just join the pump with the float system and leave over the water, connect the two cables directly at the plug and the system will work easily.
- Tamaño del conjunto: Ø 350mm x 190mm (h), longitud de cable de 10 mts.
- Altura de los chorros: 1.016mm x Ø 762mm de ancho, ajustable con la bomba.
- Las luces LED son súper brillantes con cambio de colores automático en rojo, verde, azul y combinados, no requiere controlador.
- Fácil montaje, unir la bomba con el flotador y ponerlo en el agua, conectar la bomba y la corona de LEDs a red.



### Chromed option/ Opción de Cromado

- Look for **CHROME** icon for articles that can be ordered chromed.
- Busca el icono **CHROME** para artículos que pueden pedirse cromados.



**Interested in chrome nozzles?** we have almost the entire range of nozzles in its chromed version.

**¿Interesado en las boquillas cromadas?** disponemos de casi toda la gama de boquillas en su versión cromada.



# Titan and Select Series/ Series Select y Titan

**S**elect Series ranging from 1 HP to 7.5 HP. Such compacts are the cornerstone of all floating fountains, because they offer an **impressive performance**. Safe-Rain sells this pond fountains in two different orientations to provide water intake at virtually any depth:

**L**as fuentes para estanques de la **Serie Select**: oscilan entre 1 HP y 7.5 HP. Este tipo de compactos son la piedra angular de todas las fuentes flotantes ya que **ofrecen un rendimiento impresionante**. Se comercializa en dos disposiciones diferentes lo que posibilita la toma de agua en cualquier profundidad:



- Vertical Orientation/ Orientación Vertical
- Horizontal Orientation/ Orientación Horizontal

Floating f./  
F. flotantes



**Titan Fountains** are between 7,5 HP and 40 HP and **specially designed for lakes** and have the motor and pump mounted horizontally. Advantages include a simple installation that requires little or no adjustment. The water fountain can be operated in as little as 37 inches (1,3 meters) of water and can be lit with **up to 20 submersible lights** and a choice of up to six colors. The suction screen is cleaned from a boat and is easily removed **without tools for complete cleaning**.

La serie de fuentes flotantes para lagos de la **Gama Titan** de entre 7,5 HP y 40 HP y utiliza motores sumergibles de acero inoxidable de 6 pulgadas (15,24 cm) de calidad industrial que cuentan con sellos mecánicos de carburo de silicio. Las bombas de agua están conectadas a motores cuidadosamente seleccionados entre los fabricantes líderes de la industria. Las pantallas de succión son de acero inoxidable y toda la tubería es de PVC a presión diseñada para producir pérdidas mínimas y soportar las turbulencias de las más altas velocidades de bombeo.



**VISIT OUR BLOG/ VISITA NUESTRO BLOG**

- Why is important pond and lake earation?
- Importancia de la Aireación del Agua



# FOUNTAIN NOZZLES/ BOQUILLAS PARA FUENTES

Crystalline jets/ Chorros cristalinos	Pag 31
Frothy jets/ Chorros espumosos	Pag 51
Rotatory nozzles/ Boquillas dinámicas	Pag 58
Spray features/ Chorros pulverizados	Pag 63
Spherical shapes/ Chorros esféricos	Pag 66
Bespoke nozzles/ Boquillas a medida	Pag 69

Nozzles/  
Boquillas



**N**ozzles are an important part of our catalogue, and the colorful part of any water show or architectural fountain. They are a key element in any project, as not only affect the final effect, but also water and energy consumption.

In Safe-Rain we have sorted our nozzles depending on the type of water jet produced to make it easier to get an idea of the final result. Crystalline jets, frothy jets, rotatory nozzles, spray features, spherical shapes and bespoke nozzles, also called distribution boxes. Our range of nozzles is constantly evolving, so we recommend you to visit the website in order to access an updated catalogue.

**L**as boquillas constituyen una parte importante de nuestro catálogo, y la parte más vistosa de cualquier espectáculo acuático o fuente ornamental. Son un elemento fundamental en cualquier proyecto, pues de ellas no sólo depende el efecto final, sino también el consumo de agua y el energético.

En Safe-Rain hemos clasificado nuestras boquillas en función del tipo de chorro de agua que producen, para que sea más fácil hacerse una idea del resultado final. Chorros cristalinos, chorros espumosos, boquillas dinámicas, chorros de agua pulverizados, chorros esféricos, y boquillas a medida, también llamadas cajas de reparto. Nuestra gama de boquillas está en constante desarrollo, por lo que les recomendamos visitar la web para acceder a un catálogo siempre actualizado.

# Crystalline fountain jets/ Chorros de agua cristalinos

Lance Jet I/ Chorro Lanza I	Pag 32
Lance Jet I stainless steel/ Chorro Lanza I acero inox	Pag 33
Lance jet adjustable/ Lanza regulable	Pag 34
Lance Jet II/ Chorro Lanza II	Pag 35
Lance Jet III/ Chorro Lanza III	Pag 36
Hollow jet/ Chorro hueco	Pag 37
Palm Tree jet/ Palmera	Pag 38
Willow Palm tree/ Sauce Palmera	Pag 39
Willow/ Sauce	Pag 40
Fan of jets/ Abanico de chorros	Pag 41

Laminar fan/ Abanico laminar	Pag 42
Crown of jets/ Corona de chorros	Pag 43
Special crowns with fixed jets/ Coronas especiales con lanzas fijas	Pag 44
Special crowns/ Coronas especiales	Pag 45
Calix jet/ Cáliz	Pag 46
Arum lily jet/ Flor de Cala	Pag 47
Mushroom jet/ Hongo	Pag 48
Compact crystal jet/ Cristal compacto	Pag 49
Compact rainbow jet/ Arcoiris compacto	Pag 50



Nozzles/  
Boquillas

**T**hese fountain nozzles produce a crystalline feature effect in the fountain jets and ensure that its flow inside the jet pipe is laminar. In order to prevent turbulence, all nozzles in the series are fitted with jet disturbers to “calm” the water flow. The aim is to ensure that the water jet is transparent, which means there must be no air inside it. The most representative jet produced by this jet pipe is the crystal-clear jet.

**C**on este tipo de boquillas se consigue un efecto cristalino en el agua haciendo que ésta se desplace por el interior de la tobera en régimen laminar. Para evitar turbulencias todas las boquillas de este grupo van provistas de corta chorros que “tranquilizan” el régimen del agua. El objetivo es conseguir un chorro de agua transparente, lo que implica que no lleve aire en su interior. El chorro más representativo de esta tobera es el chorro de cristal.



# Lance Jet I/ Chorro Lanza I

This serie is the most widely used in the world of water feature fountains. They are also fitted with one or two inner jet cut-offs that ensure the optimal quality of the water jet up to the heights shown on the technical data sheet. They also have a smooth ball joint that can reach a maximum slope of 20°, thereby enabling parabolic jets to be designed with no additional parts.

Esta serie es la más usada dentro del mundo de las fuentes ornamentales. Además están provistas de uno o dos cortachorros interiores que hacen que la calidad del chorro sea óptima hasta las alturas indicadas en la tabla técnica. También tienen una rótula de giro suave con la que se consigue una inclinación máxima de 20°, pudiendo hacer chorros parabólicos sin necesidad de piezas adicionales.



**CHROME**

**IN STOCK**

Brass/ Latón

Nozzles/  
Boquillas

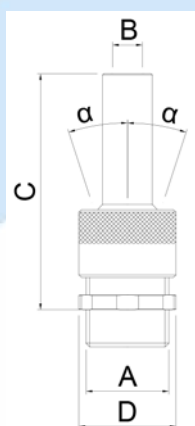

- Water appearance/ Aspecto del agua Clear/ Cristalino ★★★★★
- Wind resistance/ Resistencia al viento ★★★★★
- Splash/ Salpicadura ★★★★★
- Sound level/ Nivel de sonido ★★★★★
- Visibility/ Visibilidad ★★★★★

Accessory/ Accesorio

### Bubble level/ Nivel de burbujas

For nozzles between Ø4 and Ø19/  
Para toberas entre Ø4 y Ø19

F2303807



Dimensions/ Dimensiones							Performance/ Rendimiento													
Reference/ Referencia	Connection/ Conexión A BSP-NPT	Outlet/Salida B (mm)	Length/Long. Cx D (mm)	Straighteners/ Centradores	Angle/ Angulo (α)	Weight/ Peso (kg)	Spray height/ Altura de chorro (m)	0,5	1,0	1,5	2,0	3,0	4,0	5,0	6,0	7,0	8,0	10,0	12,0	
F2313832	G 3/8" M	Ø4	45 x Ø20	1	18°	0,05	l/min	2,3	3,3	4,3										
							m.c.a	0,7	1,5	2,2										
F2313865	G 3/8" M	Ø6	45 x Ø20	1	18°	0,05	l/min	5,0	7,2	9,0	10,5									
							m.c.a	0,6	1,1	1,6	2,2									
F2311233	G 1/2" M	Ø8	65 x Ø23	1	12°	0,10	l/min	12,0	14,0	16,0	20,0	25,0	29,0							
							m.c.a	0,5	1,0	1,6	2,1	3,4	4,5							
F2311266	G 1/2" M	Ø10	65 x Ø23	1	12°	0,08	l/min	15,0	22,0	27,0	31,0	39,0	45,0							
							m.c.a	0,5	1,1	1,7	2,3	3,6	4,9							
F2311031	G 1" M	Ø12	96 x Ø39	2	18°	0,34	l/min	19,0	30,0	37,0	43,0	51,0	60,0	68,0	76,0					
							m.c.a	0,6	1,3	2,0	2,6	3,8	5,0	6,4	8,0					
F2311064	G 1" M	Ø14	96 x Ø39	2	18°	0,33	l/min	26,0	41,0	49,0	56,0	72,0	84,0	92,0	100,0	107,0	114,0			
							m.c.a	0,7	1,4	2,1	2,8	4,2	6,2	7,5	8,4	9,2	10,1			
F2311536	G 1 1/2" M	Ø16	142 x Ø55	2	20°	0,90	l/min	33,0	50,0	63,0	74,0	92,0	110,0	121,0	128,0	139,0	150,0	169,0		
							m.c.a	0,4	1,0	1,7	2,3	3,5	5,2	6,1	6,7	7,5	8,5	10,0		
F2311569	G 1 1/2" M	Ø19	142 x Ø55	2	20°	0,87	l/min	46,0	70,0	89,0	104,0	130,0	144,0	159,0	176,0	188,0	202,0	231,0	261,0	
							m.c.a	0,4	1,1	1,8	2,5	4,0	4,9	5,7	6,6	7,5	8,3	10,1	11,8	



# Lance Jet I stainless steel/ Chorro Lanza I acero inox

Series that is 100% Stainless Steel AISI 304 made ( AISI 316 Optional ), with the maximum resistance to corrosion, oxidation and abrasion, is the most widely used in the world of water feature fountains, developed to set a new quality standard in the market. They are also fitted with one or two inner jet water straighteners that ensure the optimal quality of the water jet up to the heights shown on the technical data sheet. They also have a smooth ball joint that can reach a maximum slope of 20°, thereby enabling parabolic jets to be designed with no additional parts.

Serie fabricada 100% en Acero Inoxidable AISI 304 (AISI 316 Opcional), con la máxima resistencia a la corrosión, oxidación y abrasión, es la más usada dentro del mundo de las fuentes ornamentales, que hemos desarrollado para establecer un nuevo estándar de calidad. Provistas de uno o dos cortachorros interiores que hacen que la calidad del chorro sea óptima hasta las alturas indicadas en la tabla técnica. También tienen una rótula de giro suave con la que se consigue una inclinación máxima de 20°, pudiendo hacer chorros parabólicos sin necesidad de piezas adicionales.



Nozzles/  
Boquillas

**AISI 304**

**ON STOCK**

**Stainless steel/  
Acero Inoxidable**

Optional/ Opcional

**AISI 316**

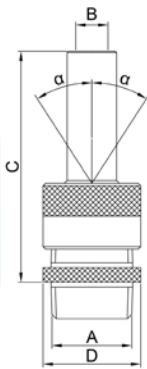

Water appearance/ Aspecto del agua **Clear/ Cristalino** ★★★★★  
 Wind resistance/ Resistencia al viento ★★★★★  
 Splash/ Salpicadura ★★★★★  
 Sound level/ Nivel de sonido ★★★★★  
 Visibility/ Visibilidad ★★★★★

Accessory/ Accesorio

**Bubble level/ Nivel de burbujas**

For nozzles between Ø4 and Ø19/  
Para toberas entre Ø4 y Ø19

**F2303807**

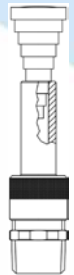

Dimensions/ Dimensiones							Performance/ Rendimiento										
Reference/ Referencia	Connection/ Conexión A BSP-NPT	Outlet/Salida B (mm)	Length/ Long. Cx D (mm)	Straighteners/ Centradores	Angle/ Ángulo (α)	Weight/ Peso (kg)	Spray height/ Altura de chorro (m)	0,5	1,0	1,5	2,0	3,0	4,0	5,0	6,0		
F2353836	G 3/8" M	Ø4	45 x Ø20	1	18°	0,05	l/min	2,3	3,3	4,3							
							m.c.a	0,7	1,5	2,2							
F2353869	G 3/8" M	Ø6	45 x Ø20	1	18°	0,05	l/min	5,0	7,2	9,0	10,5						
							m.c.a	0,6	1,1	1,6	2,2						
F2351237	G 1/2" M	Ø8	65 x Ø23	1	12°	0,10	l/min	12,0	14,0	16,0	20,0	25,0	29,0				
							m.c.a	0,5	1,0	1,6	2,1	3,4	4,5				
F2351261	G 1/2" M	Ø10	65 x Ø23	1	12°	0,08	l/min	15,0	22,0	27,0	31,0	39,0	45,0				
							m.c.a	0,5	1,1	1,7	2,3	3,6	4,9				
F2351035	G 1" M	Ø12	96 x Ø39	2	18°	0,34	l/min	19,0	30,0	37,0	43,0	51,0	60,0	68,0	76,0		
							m.c.a	0,6	1,3	2,0	2,6	3,8	5,0	6,4	8,0		
F2351068	G 1" M	Ø14	96 x Ø39	2	18°	0,33	l/min	26,0	41,0	49,0	56,0	72,0	84,0	92,0	100,0		
							m.c.a	0,7	1,4	2,1	2,8	4,2	6,2	7,5	8,4		
F2351531	G 1 1/2" M	Ø16	142 x Ø55	2	20°	0,90	l/min	33,0	50,0	63,0	74,0	92,0	110,0	121,0	128,0		
							m.c.a	0,4	1,0	1,7	2,3	3,5	5,2	6,1	6,7		
F2351564	G 1 1/2" M	Ø19	142 x Ø55	2	20°	0,87	l/min	46,0	70,0	89,0	104,0	130,0	144,0	159,0	176,0		
							m.c.a	0,4	1,1	1,8	2,5	4,0	4,9	5,7	6,6		

# Lance jet adjustable flow/ Lanza regulable

In this new series we have added to the most used nozzle the most common complement: a valve for regulating and adjusting the flow rate; We have achieved this without losing the functionality of the ball joint that allows tilting and thus achieve the parabolic shots without the need for additional pieces. This element has been developed with the least possible effect on the water regime, compact design, avoiding the use of a hand for regulation, which in most cases are manufactured in Iron that must be removed from the fountain after adjustment for avoid the production of oxidations. This new series therefore shortens the installation time by reducing the number of parts needed while maintaining performance and utilities.

En esta nueva serie hemos añadido a la boquilla más usada el complemento más habitual: una válvula para la regulación y ajuste del caudal; lo hemos logrado sin perder la funcionalidad de la rótula que permite inclinación y así lograr tiros parabólicos sin necesidad de piezas adicionales. Se ha desarrollado un elemento con el menor efecto posible sobre el régimen del agua, diseño compacto, evitando el empleo de manecilla para la regulación, que en la mayoría de los casos son fabricadas en Hierro y se deben retirar de la fuente tras el ajuste para evitar la oxidación. Esta nueva serie acorta por lo tanto el tiempo de instalación al reducir el número de piezas necesarias manteniendo las prestaciones y utilidades. Es la mejor opción en los casos donde el especialista en fuentes haya decidido que la válvula es necesaria.



- Water appearance/ Aspecto del agua Clear/ Cristalino ★★★★★
- Wind resistance/ Resistencia al viento ★★★★★
- Splash/ Salpicadura ★★★★★
- Sound level/ Nivel de sonido ★★★★★
- Visibility/ Visibilidad ★★★★★

Brass / Latón



Accessory/ Accesorio

## Bubble level/ Nivel de burbujas

For nozzles between Ø4 and Ø19/  
Para toberas entre Ø4 y Ø19

F2303807

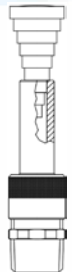

Dimensions/ Dimensiones							Performance/ Rendimiento									
Reference/ Referencia	Connection/ Conexión A BSP-NPT	Outlet/Salida B (mm)	Length/Long. Cx D (mm)	Straighteners/ Centradores	Angle/ Angulo (α)	Weight/ Peso (kg)	Spray height/ Altura de chorro (m)	0,5	1	1,5	2	3	4	5	6	
F2303831	G 3/8" M	Ø4	50 x Ø22	1	18°	0,05	l/min	2,2	3,4	4,2						
							m.c.a	0,8	1,6	2,3						
F2303864	G 3/8" M	Ø6	50 x Ø22	1	18°	0,05	l/min	5,0	7,1	9,2						
							m.c.a	1,2	2,4	3,7						
F2301232	G 1/2" M	Ø8	88 x Ø30	2	12°	0,15	l/min	12	14	17	21	26				
							m.c.a	0,8	1,5	2,3	3,2	4,8				
F2301265	G 1/2" M	Ø10	88 x Ø30	2	12°	0,15	l/min	16	23	28	32	39				
							m.c.a	1,2	2,3	3,4	4,6	7,2				
F2301039	G 1" M	Ø12	130 x Ø44	2	18°	0,60	l/min	22	30	37	44	53	62	69	75	
							m.c.a	0,8	1,5	2,4	3,3	4,8	6,4	7,8	9,1	
F2301063	G 1" M	Ø14	130 x Ø44	2	18°	0,60	l/min	28	41	50	57	72	83	92	101	
							m.c.a	1,1	2,1	3,1	4,1	6,3	8,2	10,2	12,2	

Further information at [www.saferain.com](http://www.saferain.com) | Más información en [www.saferain.com](http://www.saferain.com)

# Lance Jet II/ Chorro Lanza II

Nozzles serie suited to **greater heights** in outdoor architectural fountains. They are cast in brass before being machined and fitted with a flange-ball joint, which is designed to correct the tilt of the actual installation rather than create parabolic water jets, since tilt levels of around 8° can be achieved. They are also fitted with a jet locator or cut-off to ensure a **perfect water column**.

Serie de boquillas indicadas para **grandes alturas** en fuentes ornamentales de exterior. Fabricadas en latón mediante la técnica de fundición y posterior mecanizado, están provistas de brida-rótula, pero con la finalidad de corregir las inclinaciones propias de la instalación y no con la intención de hacer chorros de agua parabólicos, pues se consiguen inclinaciones de en torno a 8°. Igualmente van provistas de un centrador modular, o cortachorros, para garantizar la **perfecta columna de agua**.



**CHROME**

**ON STOCK**

Brass/ Latón

✔ Straighteners/ Centradores

Water appearance/ Aspecto del agua Clear/ Cristalino ★★★★★  
 Wind resistance/ Resistencia al viento ★★★★★  
 Splash/ Salpicadura ★★★★★  
 Sound level/ Nivel de sonido ★★★★★  
 Visibility/ Visibilidad ★★★★★

Nozzles/  
Boquillas

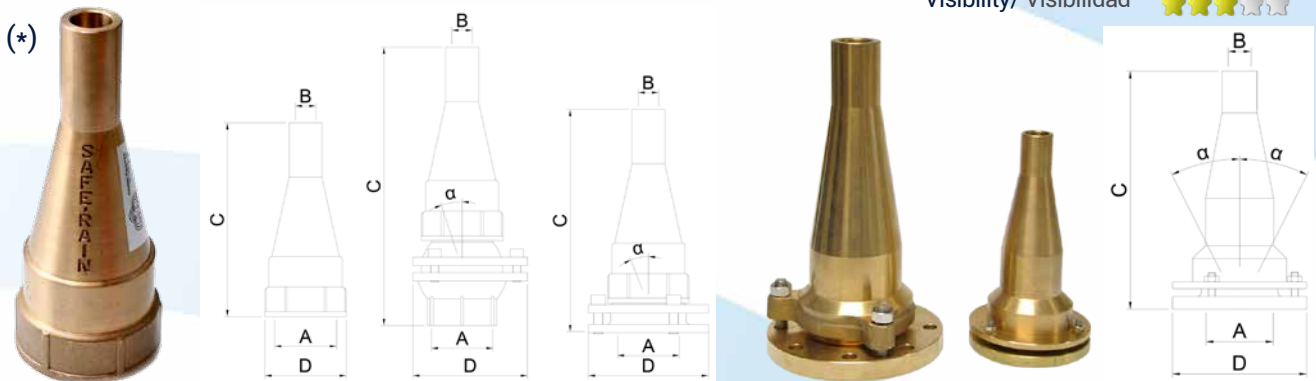

Dimensions/ Dimensiones										Performance/ Rendimiento											
Reference/ Referencia	Integrated flange/ Rótula incorporada	Without flange/ Sin rótula	With balla joint/ Con rótula bola	With flange/ Con rótula brida	Connection/ Conexión A BSP	Adaptor/ Adaptador BSP-NPT	Outlet/ Salida B (mm)	Length/ Long. CxD (mm)	Angle/ Ángulo (α)	Weight/ Peso (kg)	Spray height/ Altura de chorro (m)	1	3	5	7	9	10	15	20		
F2322538	✔				G 2 1/2" F/H	F7380257 2 1/2" M-M	Ø25	256x Ø146	10°	5,20	l/min	147	248	310	370	420	440				
F2322562	✔				G 2 1/2" F/H		Ø29	256x Ø146	10°	5,00	l/min	194	347	440	530	575	620	750			
F2323001 (*)		✔			G 3" F/H	F7380303 3" M-M	Ø25	230x Ø100	-	1,73	l/min	147	246	310	370	420	440				
F2323034 (*)		✔			G 3" F/H		Ø29	230x Ø100	-	1,72	l/min	194	347	440	530	575	620	750			
F2323056 (*)			✔		G 3" F/H		Ø25	272x Ø146	7°	3,93	l/min	147	246	310	370	420	440				
F2323067 (*)			✔		G 3" F/H		Ø29	272x Ø146	7°	3,92	l/min	194	347	440	530	575	620	750			
F2323012 (*)				✔	G 3" F/H		Ø25	355x Ø186	20°	6,38	l/min	147	246	310	370	420	440				
F2323045 (*)				✔	G 3" F/H		Ø29	355x Ø186	20°	6,37	l/min	194	347	440	530	575	620	750			
F2324035	✔				DN 100			Ø38	370x Ø212	8°	14,5	l/min	235	535	673	797	903	952	1166	1347	
F2324068	✔				DN 100			Ø44	370x Ø212	8°	13,5	l/min	444	770	993	1175	1333	1405	1721	1987	
F2326037	✔				DN 150		Ø64	545x Ø297	9°	35,5	l/min	983	1702	2197	2600	2948	3108	3806	4395		
F2326061	✔				DN 150		Ø76	545x Ø297	9°	32,8	l/min	1386	2400	3099	3666	4157	4382	5367	6197		



# Lance Jet III/ Chorro Lanza III

These fountain nozzles are similar to the two previous models in terms of their operating principle. Its manufacture uses **more economical** materials and manufacturing techniques than the previous two series. In this model, the brass body is replaced by an AISI 304 stainless steel casing. Because the previous series have a smaller deflection cone at great heights, they perform better; however, for the first three quarters of the water jet height, they both provide similar quality. They are supplied with an outer swivel joint or with no joint.

Estas toberas son similares a las dos series anteriores en cuanto a principio de funcionamiento. Para su fabricación usamos materiales y técnicas de fabricación **más económicas** que la anterior. Se sustituye el cuerpo principal de latón por acero inoxidable AISI 304. Al llevar un cono deflector menor a grandes alturas el comportamiento de la serie anterior es mejor, pero en los tres primeros cuartos del chorro de agua ambas calidades son similares. Se comercializan con rótula externa o sin rótula.



Nozzles/  
Boquillas



- Water appearance/ Aspecto del agua: Clear/ Cristalino
- Wind resistance/ Resistencia al viento: ★★★★★
- Splash/ Salpicadura: ★★★★★
- Sound level/ Nivel de sonido: ★★★★★
- Visibility/ Visibilidad: ★★★★★

**Brass + Stainless steel/  
Latón + Acero Inoxidable**

Straighteners/ Centradores

Dimensions/ Dimensiones							Performance/ Rendimiento											
Reference/ Referencia	With flange/ Con rótula brida	With ball joint/ Con rótula bola	Connection/ Conexión A	Outlet/ Salida B	Length/ Long. CxD (mm)	Weight/ Peso (Kg)	Spray height/ Altura de chorro (m)	1	3	5	7	9	10	15	20	30	40	60
F2342002			G 2"F/H	Ø25	178,5xØ71	0,90	l/min	143	247	319	378	428	452	553				
F2342057		✓			266xØ116	2,94	m.c.a	1,20	3,60	6,00	8,40	10,8	12,0	18,0				
F2342013			G 2"F/H	Ø30	178,5xØ71	0,88	l/min	206	356	460	544	617	651	796	920			
F2342068		✓			266xØ116	2,92	m.c.a	1,20	3,60	6,00	8,40	10,8	12,0	18,0	24,0			
F2343003					300xØ102	2,40	l/min	366	633	817	967	1097	1157	1416	1635	1990		
F2343036	✓		G 3"F/H	Ø40	355xØ146	4,60												
F2343058		✓			420xØ163	7,05	m.c.a	1,20	3,60	6,00	8,40	10,8	12,0	18,0	24,0	36,0		
F2343014					300xØ102	2,30	l/min	527	912	1177	1393	1580	1665	2039	2355	2887	3330	
F2343047	✓		G 3"F/H	Ø48	355xØ146	4,50												
F2343069		✓			420xØ163	6,95	m.c.a	1,20	3,60	6,00	8,40	10,8	12,0	18,0	24,0	36,0	48,0	
F2343025					360xØ102	3,30	l/min	1120	1940	2503	2962	3360	3542	4336	5008	6114	7082	8675
F2343082	✓		G 3"F/H	Ø70	415xØ146	5,50												
F2343071		✓			480xØ163	7,95	m.c.a	1,20	3,60	6,00	8,40	10,8	12,0	18,0	24,0	36,0	48,0	72,0

Further information at [www.saferain.com](http://www.saferain.com) | Más información en [www.saferain.com](http://www.saferain.com)

# Hollow Jet/ Chorro Hueco

The hollow jet nozzle achieves the same performance as the lance jet nozzle III, but with considerable savings in flow and energy.

The water jet, being hollow, requires less power in a pump than its equivalent in lance jets, which means **significant energy savings** in operation due to **low power consumption of the pump**.

La boquilla de chorro hueco consigue las mismas prestaciones que el de chorro de lanza III pero con un considerable ahorro de caudal y energético.

El chorro, al ser hueco, requiere una bomba de menor potencia que su equivalente en los chorros de lanza y esto implica un **importante ahorro energético** en el funcionamiento debido al **menor consumo eléctrico de la bomba**.

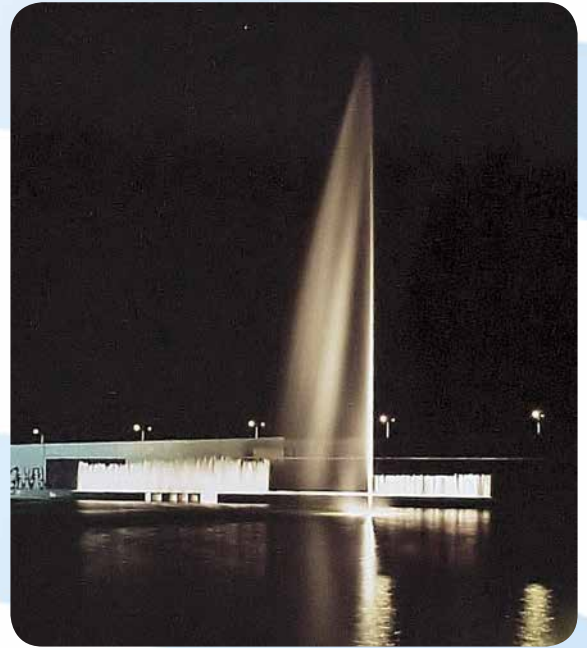

Nozzles/  
Boquillas

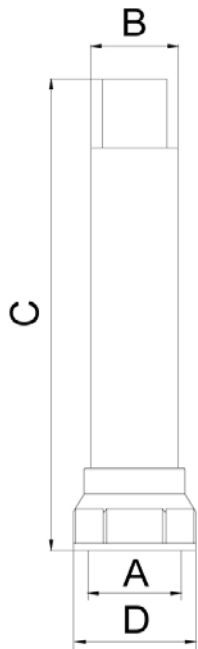

- Water appearance/ Aspecto del agua: Clear/ Cristalino (5 stars)
- Wind resistance/ Resistencia al viento: (5 stars)
- Splash/ Salpicadura: (4 stars)
- Sound level/ Nivel de sonido: (4 stars)
- Visibility/ Visibilidad: (4 stars)

**Brass + Stainless steel**  
**Latón + Acero Inoxidable**

**AISI 304**

**ON STOCK**

✔ Straighteners/ Centradores

Dimensions/ Dimensiones							Performance/ Rendimiento								
Reference/ Referencia	Connection/ Conexión A BSP	Outlet/ Salida B (mm)	Length/ Long. C x D (mm)	Suction filter/ Filtro succión	Balljoint/ Rótula	Weight/ Peso (kg)	Spray height/ Altura de chorro (m)	1	3	5	7	9	10	15	20
F2333002	3" F/H	Ø48	327 x Ø101	2	⊗	2,2	l/min	168	305	405	478	525	550		
							m.c.a	1,80	5,00	8,00	11,40	14,30	15,90		
F2333013	3" F/H	Ø70	409 x Ø102	2	⊗	3,1	l/min	395	700	920	1120	1390	1510	1870	
							m.c.a	1,60	4,10	6,60	9,70	12,20	13,50	17,50	
F2335004	DN125	Ø125	701 x Ø247	2	✔	15,2	l/min	1583	2333	3000	3667	4350	4700	5720	6060
							m.c.a	1,70	4,50	7,60	11,00	14,00	15,60	20,30	21,80

Más información en [www.saferain.com](http://www.saferain.com) | Further information at [www.saferain.com](http://www.saferain.com)

# Palm Tree Jet/ Palmera

Simple fountain nozzle comprised of a set of 4 mm water jets arranged in such a way that on rising they look like the trunk of a palm tree and on falling like its leaves. The angle given to the jets means that, from wherever they are positioned, spectators can see the front and back jets cross over producing an **esthetic effect of great beauty in the architectural fountain**. The range is comprised of four sizes with 16, 20, 50 and 59 fountain jets.

Boquilla compuesta por un conjunto de chorros de 4mm dispuestos de tal forma que en su ascensión simulan el tronco de una palmera y en su caída las hojas de la misma. La inclinación dada a los chorros de agua hace que el espectador vea desde su posición los cruces de los delanteros con los traseros provocando un **efecto de gran belleza estética en la fuente ornamental**. La familia está compuesta por cuatro tamaños con 16, 20, 50 y 60 chorros de agua.



Nozzles/  
Boquillas



Brass/ Latón

✔ Straighteners/ Centradores

Water appearance/ Aspecto del agua Clear/ Cristalino  
 Wind resistance/ Resistencia al viento ★★★★★  
 Splash/ Salpicadura ★★★★★  
 Sound level/ Nivel de sonido ★★★★★  
 Visibility/ Visibilidad ★★★★★

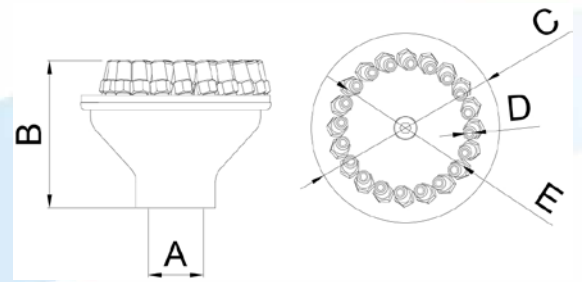

Dimensions/ Dimensiones							Performance/ Rendimiento							
Reference/ Referencia	Connection/ Conexión A BSP	Length/ Long. B x C (mm)	Outlet/ Salida D (mm)	Jets number/ Número de chorros	Length/ Long. E (mm)	Weight/ Peso (kg)	Spray height/ Altura de chorro (m)	0,5	1,0	1,5	2,0	2,5	3,0	3,5
F2441024	G 1" F/H	64 x 87	Ø4	16	Ø60	1,03	l/min	42	55	66				
							m.c.a	0,7	1,4	2,2				
							Diameter (cm)	80	140	200				
F2441305	G 1½" F/H	90 x 113	Ø4	20	Ø81	1,14	l/min	50	68	85	100			
							m.c.a	0,6	1,4	2,3	3,3			
							Diameter (cm)	110	190	250	350			
F2442508	G 2½" F/H	150 x 258	Ø4	50	Ø198	7,10	l/min		174	218	250	285	310	
							m.c.a		1,2	2,0	2,8	3,6	4,4	
							Diameter (cm)		220	320	420	520	620	
F2443004	G 3" F/H	182 x 312	Ø4	59	Ø236	13,80	l/min		200	240	290	330	370	400
							m.c.a		1,5	2,0	2,7	3,4	4,4	5,2
							Diameter (cm)		220	320	420	520	620	720

Más información en [www.saferain.com](http://www.saferain.com) | Further information at [www.saferain.com](http://www.saferain.com)



# Willow- Palm tree/ Sauce -Palmera

In our constant search to develop new nozzles, the technical department of SAFE RAIN has integrated the **Palm tree nozzle and the Willow nozzle**, combining the spectacularity and beauty of both. **The palm tree rises majestically in the centre**, surrounded by the willow of lower height, the result is simply magnificent, full of elegance and very original. Highly recommended for medium and large outdoor fountains.

En nuestra búsqueda constante por desarrollar nuevas boquillas, el departamento técnico de SAFE RAIN ha integrado la **boquilla Palmera y la Boquilla Sauce**, aunando la espectacularidad y belleza de ambas. **La palmera se eleva majestuosa en el centro**, rodeada por el sauce de menor altura, el resultado es sencillamente magnifico, lleno de elegancia y muy original. Muy recomendable para fuentes de exterior de tamaño medio y grande.



Nozzles/  
Boquillas



Brass/ Latón

✔ Straighteners/ Centradores

Water appearance/ Aspecto del agua Clear/ Cristalino ★★★★★  
 Wind resistance/ Resistencia al viento ★★★★★  
 Splash/ Salpicadura ★★★★★  
 Sound level/ Nivel de sonido ★★★★★  
 Visibility/ Visibilidad ★★★★★

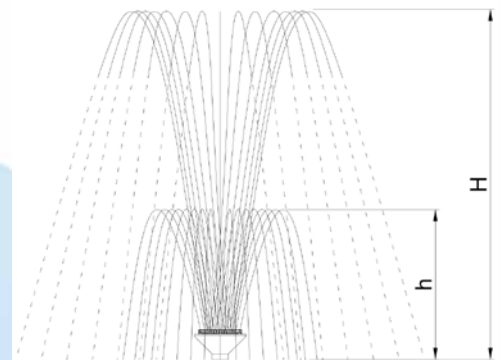
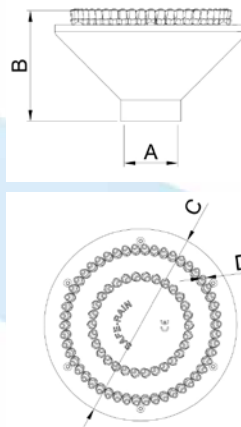

Dimensions/ Dimensiones							Performance/ Rendimiento					
Reference/ Referencia	Connection/ Conexión A BSP	Adaptor/ Adaptador BSP-NPT	Length/ Long. B x C (mm)	Outlet/ Salida D (mm)	Jets number/ Número de chorros	Weight/ Peso (kg)	Spray height/ Altura de chorro (m) H	1,0	1,5	2,0	2,5	3,0
<b>F2412505</b>	G 2½" F/H	F7380257 2½" M-M	150xØ258	Ø4	80	7,40	Height/ Altura (m) h	0,40	0,60	0,90	1,10	1,25
l/min							220	255	295	322	360	
m.c.a							1,10	1,80	2,60	3,30	4,00	
Diameter (cm)							200	290	360	440	500	
<b>F2413001</b>							G 3" F/H	F7380303 3" M-M	182xØ312	Ø4	104	13,90
l/min	253	335	400	448	490							
m.c.a	1,20	2,00	2,80	3,50	4,40							
Diameter (cm)	220	310	380	460	550							

Más información en [www.saferain.com](http://www.saferain.com) | Further information at [www.saferain.com](http://www.saferain.com)

# Willow Tree/ Sauce

**B**rass made nozzle, molds water emulating the shape of the Willow tree, the water rises in a parabola to the outside and then descend remembering the shape of this beautiful ornamental tree. Available in 4 sizes with 16, 20, 50 and 59 jets, which allows you to always find the nozzle that fits the size of any pond.

**B**oquilla fabricada en latón, moldea el agua emulando la forma del Sauce, el agua asciende en una parábola hacia el exterior para posteriormente descender recordando la forma de este precioso árbol ornamental. Disponible en 4 tamaños con 16, 20, 50 y 59 chorros, lo que permite encontrar siempre la boquilla que se adapta al tamaño de cualquier fuente.



**CHROME**

**ON STOCK**

Brass/ Latón

- Water appearance/ Aspecto del agua Clear/ Cristalino
- Wind resistance/ Resistencia al viento ★★★★★
- Splash/ Salpicadura ★★★★★
- Sound level/ Nivel de sonido ★★★★★
- Visibility/ Visibilidad ★★★★★

✔ Straighteners/ Centradores

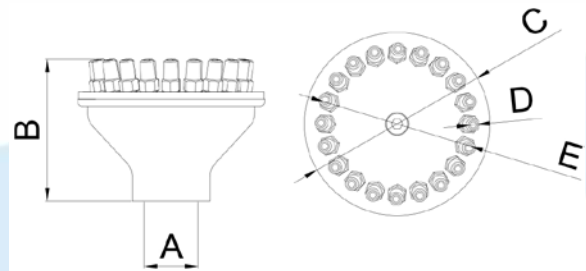

Dimensions/ Dimensiones								Performance/ Rendimiento						
Reference/ Referencia	Conexión/ Conexión A BSP	Length/ Long. B x C (mm)	Outlet/ Salida D (mm)	Jets number/ Número de chorros	Length/ Long. E (mm)	Weight/ Peso (kg)	Spray height/ Altura de chorro (m)	0,5	1,0	1,5	2,0	2,5	3,0	3,5
F2421009	G 1" H	67 x 84	Ø4	16	Ø64	1,03	l/min	43	61	75				
							m.c.a	0,6	1,4	2,7				
							Diameter (cm)	80	150	190				
F2421303	G 1 1/4" H	90 x 113	Ø4	20	Ø97	1,14	l/min	50	74	93	108			
							m.c.a	0,6	1,5	2,2	2,9			
							Diameter (cm)	100	175	250	300			
F2422506	G 2 1/2" H	150 x 258	Ø4	50	Ø215	7,10	l/min		162	195	240	275	290	
							m.c.a		1,3	1,9	2,8	3,7	4,0	
							Diameter (cm)		150	200	275	325	350	
F2423002	G 3" H	182 x 312	Ø4	59	Ø247	13,80	l/min		190	240	280	312	345	377
							m.c.a		1,4	2,0	2,6	3,3	4,0	4,9
							Diameter (cm)		100	150	250	320	400	450

Más información en [www.saferain.com](http://www.saferain.com) | Further information at [www.saferain.com](http://www.saferain.com)



# Fan of jets/ Abanico de chorros

This fountain nozzle is a water manifold that houses up to 21 divergent lance jets, with 4 mm diameter jet nozzle heads. Because of the outlet angle, these jets are also parabolic, i.e. **it combines both patterns: divergent fans and parabolic water jets**. It is usually used in **outdoor fountains and swimming pools** as a secondary feature. To keep the jets compact, heights of over 5 metres are not recommended.

Esta boquilla es un colector de agua que alberga hasta 21 chorros de lanza divergentes y de 4mm de diámetro. Debido al ángulo de salida, dichos chorros son a su vez parabólicos, es decir, **combina dos efectos: chorros de agua parabólicos y divergentes**. Se utiliza habitualmente en **fuentes de exterior y en piscinas** como efectos secundarios. Para que los chorros se mantengan compactos no se aconseja un alcance mayor de 5 m.



- Water appearance/ Aspecto del agua Clear/ Cristalino ★★★★★
- Wind resistance/ Resistencia al viento ★★★★★
- Splash/ Salpicadura ★★★★★
- Sound level/ Nivel de sonido ★★★★★
- Visibility/ Visibilidad ★★★★★

Nozzles/  
Boquillas

**CHROME**

**ON STOCK**

Brass/ Latón

✔ Straighteners/ Centradores

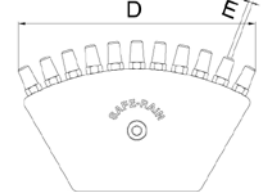
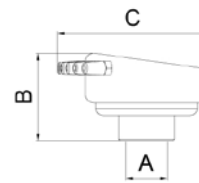
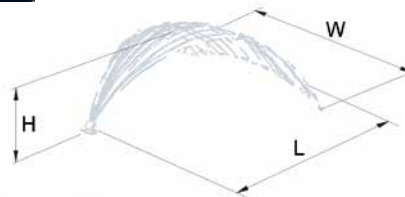

Reference/ Referencia	Connect./ Conexión A BSP-NPT	Length/ Long. B x C (mm)	Length/ Long. D (mm)	Outlet/Salida E (mm)	Jets No/ N° de chorros	Angle/ Ángulo	Weight/ Peso (kg)	Performance/ Rendimiento					
								Horizontal range/ Alcance horizontal (m) L	1	2	3	4	5
F2751006	G 1" F/H	62 x 107	168,5	Ø4	11	30°	1,280	l/min	30	51	66	76	78
								m.c.a	1,15	2,20	2,90	3,55	4,00
								H x W (mm)	144x 1200	268x 2050	433x 2700	577x 3150	722x 3500
								l/min	35	47	55	59	62
								m.c.a	1,20	1,80	2,20	2,50	2,65
								H x W (mm)	250x 2200	500x 3200	750x 3850	1000x 4300	1250x 4500
F2751017	G 1" F/H	62 x 107	168,5	Ø4	21	30°	1,365	l/min	55	85	110	128	137
								m.c.a	1,05	2,00	2,75	3,30	3,70
								H x W (mm)	144x 1050	266x 1850	433x 2500	577x 2900	722x 3100
								l/min	53	80	102	120	136
								m.c.a	1,05	1,70	2,10	2,40	2,55
								H x W (mm)	250x 1250	500x 2200	750x 2850	1000x 3250	1250x 3450

Más información en [www.saferain.com](http://www.saferain.com) | Further information at [www.saferain.com](http://www.saferain.com)

# Laminar fan/ Abanico laminar

This nozzle generates a narrow **film of water** that widens out over its parabolic trajectory due to the exit angle. It is **commonly used in outdoor water fountains and swimming pools** in combination with other main features.

Esta boquilla genera una **lámina de agua** estrecha en la salida que va ensanchando conforme avanza en su trayectoria parabólica debido al ángulo de salida. Se **suele utilizar en fuentes de exterior y en piscinas** combinándose con otros efectos principales.

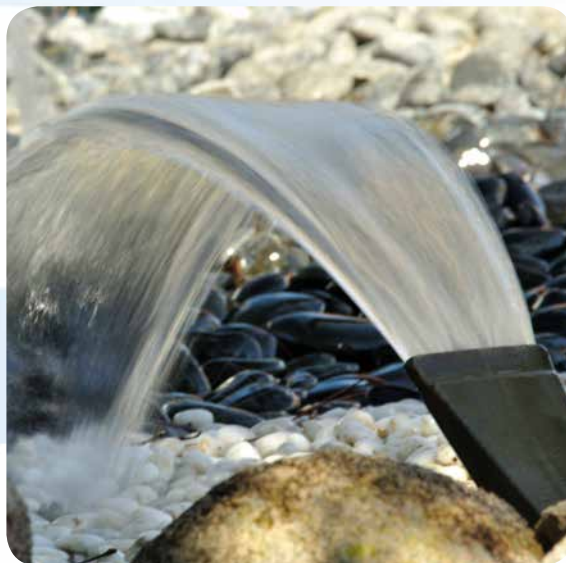

**CHROME**

**ONESTOCK**

Brass/ Latón

Nozzles/  
Boquillas

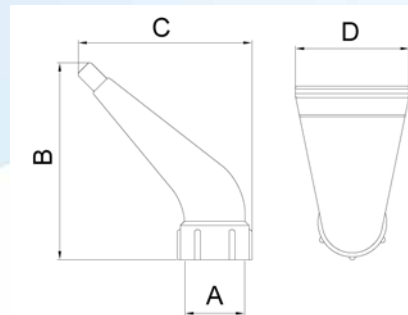
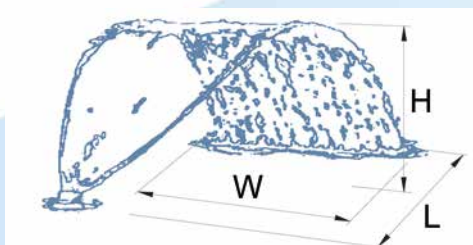

Water appearance/ Aspecto del agua Clear/ Cristalino ★★★★★  
 Wind resistance/ Resistencia al viento ★★★★★  
 Splash/ Salpicadura ★★★★★  
 Sound level/ Nivel de sonido ★★★★★  
 Visibility/ Visibilidad ★★★★★

Dimensions/ Dimensiones							Performance/ Rendimiento					
Reference/ Referencia	Connection/ Conexión A BSP-NPT	Length/ Long. B x C (mm)	Length/ Long. D (mm)	Jets thick- ness/ Espe- sor lámina (mm)	Weight/ Peso (kg)	Spray range/ Alcance de chorro (m) L	0,5	1	2	3	4	5
F2693406	G 3/4"F/H	98 x 86	56,5	3	0,37	l/min	29	34	38			
						m.c.a	1,00	1,35	1,78			
						H x W (mm)	120x 220	250x 380	500x 700			
F2691009	G 1"F/H	149 x 120	88	4	0,79	l/min	40	60	95	122		
						m.c.a	0,50	1,00	1,70	2,10		
						H x W (mm)	120x 310	250x 530	500x 980	750x 1410		
F2691505	G 1½"F/H	178,5 x 147	119	5	1,25	l/min	67	106	165	212	250	280
						m.c.a	0,25	0,50	1,00	1,40	1,70	1,90
						H x W (mm)	120x 450	250x 780	500x 1400	750x 2000	1000x 2700	1250x 3300

Más información en [www.saferain.com](http://www.saferain.com) | Further information at [www.saferain.com](http://www.saferain.com)

# Crown of jets/ Corona de chorros

These nozzles are jet manifolds that combine various tilt angles to produce a variety of water falls at different heights. **This nozzle, on its own, is able to fill both small and large diameter ponds** due to the wide range of sizes available.

Estas boquillas son colectores de chorros libres que se combinan con distintas inclinaciones para conseguir diferentes caídas y alturas. **Esta tobera es capaz de llenar el vaso de una fuente, sea éste de pequeño o gran diámetro, debido a la gran variedad de tamaños existentes.**

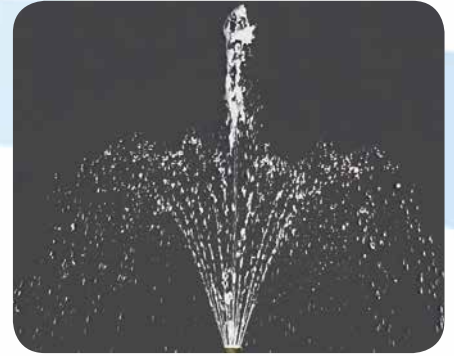

Brass/ Latón

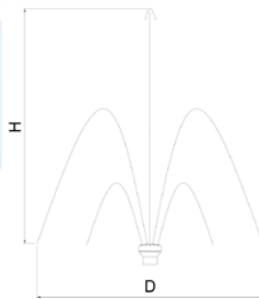

Water appearance/ Aspecto del agua Clear/ Cristalino  
 Wind resistance/ Resistencia al viento ★★★★★  
 Splash/ Salpicadura ★★★★★  
 Sound level/ Nivel de sonido ★★★★★  
 Visibility/ Visibilidad ★★★★★

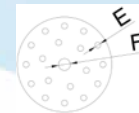

**CHROME**  
**ON STOCK**

Nozzles/  
Boquillas

Dimensions/ Dimensiones						Performance/ Rendimiento						
Reference/ Referencia	Water shape/ Forma del agua	Connection/ Conexión A BSP-NPT	Length/ Long. B x C (mm)	Jets number/ Número de chorros (mm)	Weight/ Peso (kg)	Spray height/ Altura de chorro (m) H	0,5	1,0	1,5	2,0	2,5	3,0
F2803419		G¾" F/H	46 x Ø48	6 (Ø3)	0,29	l/min	8,0	11,5	16,5	21,0		
						m.c.a	1,0	1,8	2,7	3,8		
						Diameter (cm) D	130	200	260	310		
F2803421		G¾" F/H	46 x Ø48	6 (Ø3) 1 (Ø6)	0,27	l/min	11,0	17,5	22,5	27,5		
						m.c.a	0,6	1,1	1,7	2,2		
						Diameter (cm) D	65	150	200	240		
F2803432		G¾" F/H	46 x Ø48	6 (Ø3) 6 (Ø3) 1 (Ø6)	0,25	l/min	17,0	24,5	30,7	35,0		
						m.c.a	0,6	1,1	1,7	2,2		
						Diameter (cm) D	60	145	200	240		
F2803443		G¾" F/H	46 x Ø48	12 (Ø3)	0,26	l/min	17,0	24,0	30,0	35,0		
						m.c.a	1,2	2,2	3,4	4,8		
						Diameter (cm) D	120	205	270	330		
F2803454		G¾" F/H	46 x Ø48	12 (Ø3) 1 (Ø6)	0,25	l/min	17,0	25,0	31,5	36,5		
						m.c.a	0,6	1,1	1,7	2,2		
						Diameter (cm) D	70	125	165	200		
F2803465		G¾" F/H	46 x Ø48	12(Ø3) 6 (Ø3) 1 (Ø6)	0,22	l/min	22,0	34,0	40,0	47,5		
						m.c.a	0,6	1,1	1,7	2,2		
						Diameter (cm) D	60	110	150	180		
F2801079		G1" F/H	69 x Ø84	24 (Ø3) 12 (Ø3) 1 (Ø6)	1,06	l/min	31,0	50,0	63,0	74,0	82,0	90,0
						m.c.a	0,6	1,1	1,6	2,3	2,9	3,5
						Diameter (cm) D	55	100	145	180	210	240
F2801081		G1" F/H	69 x Ø84	24 (Ø3) 12 (Ø3) 6 (Ø3) 1 (Ø6)	1,01	l/min	43,0	58,0	70,0	82,0	92,0	100,0
						m.c.a	0,6	1,1	1,6	2,2	2,8	3,2
						Diameter (cm)	36	80	118	155	190	215



# Special crowns with fixed jets/ Coronas especiales con lanzas fijas

**J**ets manifolds **without ball joint** combined with **different inclinations and disposition**. Available with several configurations valid for medium and large ponds always taking into account the aesthetic aspect, proportion and elegance. The use of the fixed lance, with 8 mm diameter outlet, which develops very consistent and almost crystalline jets, thanks to the flow quality with which the water jet leaves the nozzle, has allowed us to create a family that will surely set a trend in the market.

**C**oletores de **chorros libres fijos** sin rótula combinados con **diferentes inclinaciones y disposición**. Disponibles con varias configuraciones válidas para estanques medianos y grandes siempre teniendo en cuenta el aspecto estético, la proporción y la elegancia. El empleo de la lanza fija, con salida de 8 mm de diámetro, que desarrolla chorros muy consistentes y de aspecto casi cristalino, gracias a la calidad de flujo con la que el chorro de agua sale de la boquilla, nos ha permitido crear una familia que seguro marcará tendencia en el mercado.



Water appearance/ Aspecto del agua Clear/ Cristalino ★★★★★  
 Wind resistance/ Resistencia al viento ★★★★★  
 Splash/ Salpicadura ★★★★★  
 Sound level/ Nivel de sonido ★★★★★  
 Visibility/ Visibilidad ★★★★★

Nozzles/  
Boquillas

**CHROME** **ONESTOCK** Brass/ Latón

✔ Straighteners/ Centradores

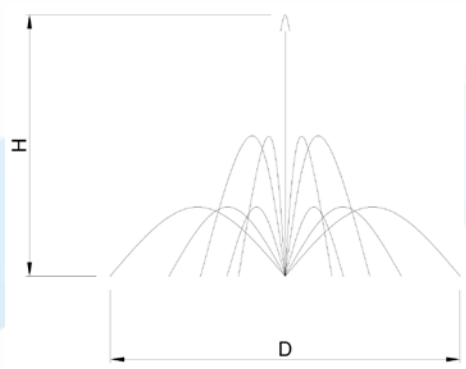
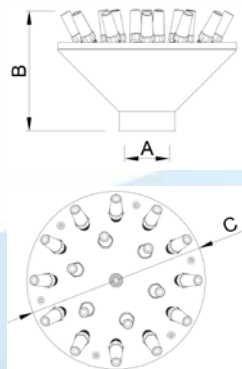

Dimensions/ Dimensiones							Performance/ Rendimiento									
Reference/ Referencia	Water shape/ Forma del agua	Connection/ Conexión A BSP	Adaptor/ Adaptador BSP-NPT	Length/ Long. B x C (mm)	Jets number/ Número de chorros	Weight/ Peso (kg)	Spray height/ Altura de chorro (m) H	1	2	3	4	5	6			
<b>F2802519</b> Volga		G 2½" F/H	F7380257 2½" M - M	221 x Ø255	12 Ø8	7,9	l/min	156	225	280	410					
	m.c.a						1,50	2,80	4,30	5,80						
	Diameter (cm) D						200	400	500	600						
<b>F2802532</b> Danubio								1 Ø8 12 Ø8	8,0	l/min	120	165	200	220	230	
	m.c.a				1,20	2,40	3,60			4,90	6,10					
	Diameter (cm) D				130	210	290			370	440					
<b>F2802521</b> Misisipi								6 Ø8 12 Ø8	8,4	l/min	190	280	350			
	m.c.a				2,30	4,90	7,80									
	Diameter (cm) D				250	450	700									
<b>F2802543</b> Sena								1 Ø8 12 Ø8	8,0	l/min	130	205	250	285		
	m.c.a	1,40	2,70	4,00	5,30											
	Diameter (cm) D	280	500	610	700											
<b>F2802554</b> Támesis					1 Ø8 6 Ø8 12 Ø8	8,5	l/min	167	220	285	330	375	425			
	m.c.a	1,20	2,70	3,90			5,20	7,90	9,00							
	Diameter (cm) D	180	280	380			500	630	770							

# Special crowns/ Coronas especiales

Jet manifolds that combine various tilt angles to produce a variety of water falls at different heights. They are equipped with internal pressure reducers, so that pressure can be distributed internally to produce circular crowns of different heights using a single water inlet. **This nozzle, on its own, is able to fill both small and large diameter ponds** due to the wide range of sizes available.

Collectores de chorros libres que se combinan con distintas inclinaciones para conseguir caídas y alturas. Están provistas de unos depresores internos para que con una sola entrada de agua se haga una distribución interna de presiones para conseguir coronas circulares a distintas alturas. **Esta tobera es capaz de llenar el vaso de una fuente**, sea éste de pequeño o gran diámetro, debido a la gran variedad de tamaños existentes.



Nozzles/  
Boquillas



Brass/ Latón

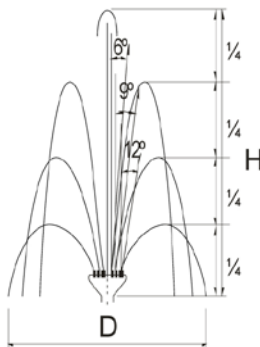

- Water appearance/ Aspecto del agua: Clear/ Cristalino (★★★★★)
- Wind resistance/ Resistencia al viento: (★★★★★)
- Splash/ Salpicadura: (★★★★★)
- Sound level/ Nivel de sonido: (★★★★★)
- Visibility/ Visibilidad: (★★★★★)

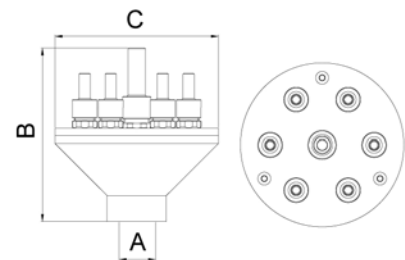

Dimensions/ Dimensiones					Performance/ Rendimiento									
Reference/ Referencia	Connection/ Conexión A BSP	Length/ Long. B x C (mm)	Jets number/ Número de chorros	Weight/ Peso (kg)	Spray height/ Altura de chorro (m) H	1	2	3	4	5	6	8	10	12
F2801305	G1 1/4" F/H	140 x Ø132	1 Ø8 6 Ø6	2,10	l/min	44	67	90	110	126	141			
					m.c.a	1,30	2,30	3,60	4,70	5,90	6,90			
					Diam. (cm) D	90	175	260	345	430	515			
F2802508	G2 1/2" F/H	221 x Ø255	1 Ø12 6 Ø8 12 Ø8	9,40	l/min	232	310	390	472	520	590	708		
					m.c.a	1,90	3,10	4,30	5,60	6,80	8,00	10,50		
					Diam. (cm) D	90	175	260	345	430	515	680		
F2803004	G3" F/H	304x Ø312	1 Ø16 6 Ø10 12 Ø8 12 Ø8	17,00	l/min	439	589	733	870	996	1108	1312	1477	1653
					m.c.a	2,20	3,50	4,60	6,30	7,30	8,80	10,60	14,60	16,70
					Diam. (cm) D	70	135	200	260	325	390	517	640	770

Further information at [www.saferain.com](http://www.saferain.com) | Más información en [www.saferain.com](http://www.saferain.com)

# Calix jet/ Cáliz

This fountain nozzle produces a more turbulent sheet of water than the mushroom jet and rises to a greater height. The film of water leaves the fountain nozzle at an exit angle to produce a parabolic pattern, and when it falls, the film is broken to create a calix shape. It generates more noise in normal operation than the mushroom jet because the film of water is broken, making it suitable for outdoor fountains as a feature combined with other higher jets.

Esta boquilla genera una lámina de agua con un régimen algo más turbulento que el hongo y que levanta más altura. Dicha lámina sale de la tobera con un ángulo de salida lo que provoca un tiro parabólico y es en su caída cuando la lámina se rompe generando una forma de cáliz. Genera más ruido en su funcionamiento normal que el hongo, lo que la hace adecuada para fuentes de exterior, como efecto combinado con otros principales.

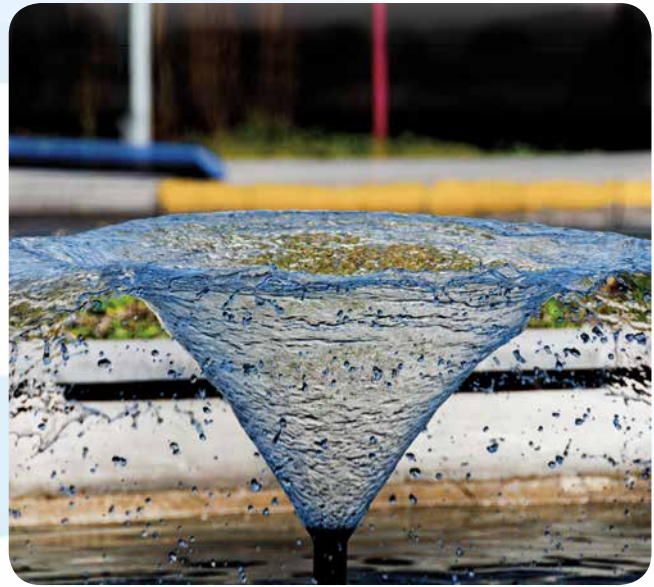

Nozzles/  
Boquillas

**Brass + Stainless steel**  
**Latón + Acero Inox.**

ON STOCK

AISI 304

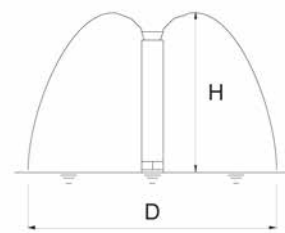
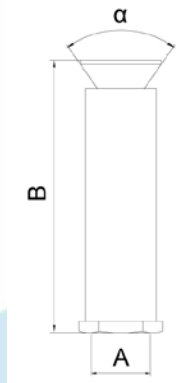

- Water appearance/ Aspecto del agua: Clear/ Cristalino (5 stars)
- Wind resistance/ Resistencia al viento: (4 stars)
- Splash/ Salpicadura: (4 stars)
- Sound level/ Nivel de sonido: (4 stars)
- Visibility/ Visibilidad: (4 stars)

Dimensions/ Dimensiones						Performance/ Rendimiento												
Reference/ Referencia	Connection/ Conexión A	Length/ Long. B (mm)	Angle/ Ángulo (α)	Jets thickness/ Espesor lámina (mm)	Weight/ Peso (kg)	Diameter/ Diametro (cm) D	40	60	80	100	120	140	160	180	200	250	300	
F2633409	G 3/4" F/H BSP-NPT	135	70°	2,0	0,30	I/min	27,0	30,5	33,5	36,0	38,0	40,0	42,0					
						m.c.a	0,74	0,84	0,92	1,00	1,06	1,12	1,18					
						Height (cm) H	27,0	31,5	36,0	40,0	44,5	48,5	53,0					
F2631003	G 1" F/H BSP-NPT	170	70°	5,0	0,60	I/min	35,0	43,0	50,0	54,5	59,0	62,0	65,5	68,0				
						m.c.a	0,90	1,10	1,30	1,55	1,75	1,95	2,18	2,40				
						Height (cm) H	31,0	37,0	41,0	45,0	48,0	51,0	53,0	55,0				
F2632004	G 2" F/H BSP	210	70°	7,0	1,00	I/min	64	75	85	95	104	114	120	125	129			
						m.c.a	0,35	0,90	0,43	0,47	0,49	0,52	0,54	0,56	0,59			
						Height (cm) H	28,0	31,0	34,0	37,0	40,0	43,0	46,0	49,0	52,0			
F2643006	G 3" F/H BSP	313	80°	5,5	4,00	I/min			110	126	134	150	158	166	174	190	206	
						m.c.a			0,50	0,55	0,56	0,60	0,65	0,72	0,80	0,95	1,10	
						Height (cm) H			37,0	42,0	45,0	50,0	53,0	57,0	60,0	80,0	100,0	

Further information at [www.saferain.com](http://www.saferain.com) | Más información en [www.saferain.com](http://www.saferain.com)



# Arum lily jet/ Flor de Cala

This fountain nozzle is a combination of two features: a central lance jetbreaking on a calix jet. The water pattern looks like an arum lily. Two sizes of fountain nozzle are available: 1" and 3" nozzle made from cast brass, machined and Stainless Steel, with a single inlet and the water distribution for the lance jet and goblet patterns takes place inside this same nozzle to provide the right height proportions for the **water jets**.

Esta boquilla para fuentes es una combinación de dos efectos: una tobera de lanza central rompiendo sobre un cáliz. El efecto acuático se asemeja a una flor de cala. Se fabrican dos tamaños de tobera: de 1" y de 3", están fabricadas en latón fundido, mecanizado y acero inoxidable, tiene sólo una entrada de agua e internamente hace la distribución para la lanza y para el cáliz consiguiendo una correcta proporción de alturas en los **chorros de agua**.



Nozzles/  
Boquillas

**Brass + Stainless steel**

**Latón + Acero Inox.**

**ONESTOCK**

**AISI 304**

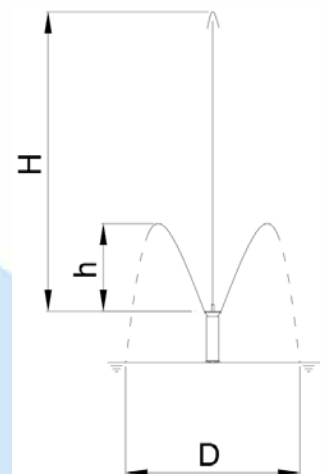
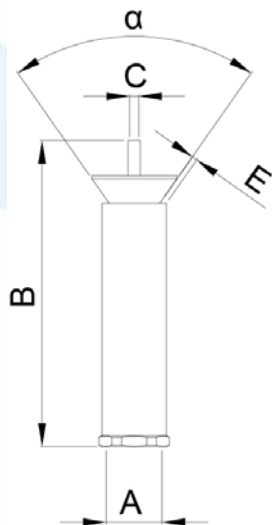

Water appearance/ Aspecto del agua Clear/ Cristalino ★★★★★  
 Wind resistance/ Resistencia al viento ★★★★★  
 Splash/ Salpicadura ★★★★★  
 Sound level/ Nivel de sonido ★★★★★  
 Visibility/ Visibilidad ★★★★★

Dimensions/ Dimensiones								Performance/ Rendimiento						
Reference/ Referencia	Connection/ Conexión A	Adaptor/ Adaptador BSP-NPT	Length/ Long. B (mm)	Outlet/ Salida C (mm)	Angle/ Ángulo (α)	Sheet thickness/ Espesor lámina E (mm)	Weight/ Peso (kg)	Spray height/ Altura de chorro (m) H	0,5	1,0	1,5	2,0	3,0	4,0
F2681008	G 1" F/H BSP-NPT	-	200	Ø4	70°	2,0	0,60	Height/ Altura (m) h	0,16	0,25	0,40	0,50		
								l/min	55	75	92	105		
								m.c.a	0,9	1,5	2,2	2,8		
								Diameter (cm)	60	120	150	200		
F2683001	G 3" F/H BSP	F7380303 3" M-M	330	Ø12	80°	5,5	4,00	Height/ Altura (m) h		0,25	0,32	0,40	0,70	0,90
								l/min		180	215	250	315	370
								m.c.a		1,5	2,1	2,6	4,1	5,6
								Diameter (cm)		150	175	200	300	400

# Mushroom jet/ Honggo

This nozzle produces a sheet of transparent water thanks to a fully laminar flow of water at the outlet. It has little wind resistance, although this also depends on the thickness of the water film. Due to its operating speed, **noise level is very low**, which makes it particularly suitable for indoor fountains. As it does not depend on the water level, it is advisable to set to a height at which the film does not break when it falls.

Esta boquilla genera una lámina de agua transparente debido al régimen totalmente laminar del agua en su salida. Tiene una escasa resistencia al viento aunque ésta depende del espesor de la lámina. Debido a su régimen de funcionamiento, **el nivel de ruido es muy escaso** lo que la hace especialmente adecuada para fuentes de interior. No depende del nivel de agua por lo que se aconseja poner a una altura que la lámina no llegue a romper en su caída.



Nozzles/  
Boquillas

**Brass + Stainless steel**

**Latón + Acero Inox.**

ON STOCK

304



Water appearance/ Aspecto del agua Clear/ Cristalino  
 Wind resistance/ Resistencia al viento ★★★★★  
 Splash/ Salpicadura ★★★★★  
 Sound level/ Nivel de sonido ★★★★★  
 Visibility/ Visibilidad ★★★★★

Dimensions/ Dimensiones					Performance/ Rendimiento							
Reference/ Referencia	Connection/ Conexión A	Length/ Long. B x C (mm)	Jets thickness/ Espesor lámina (mm)	Weight/ Peso (kg)	Diameter/ Diametro (cm)	20	30	40	50	60	80	100
F2613429	G ¾" F/H BSP-NPT	290 x Ø35	5	0,49	l/min	18,0	20,0	22,0	24,0			
					m.c.a	0,40	0,42	0,44	0,45			
F2613407	G ¾" F/H BSP-NPT	390 x Ø35	5	0,60	l/min	18,0	23,3	27,5	32,0			
					m.c.a	0,66	0,74	0,80	0,85			
F2612035	G 2" M BSP	350 x Ø54	5	1,33	l/min			34,0	35,5	37,0	43,0	50,0
					m.c.a			0,50	0,55	0,60	0,70	0,80
F2612068	G 2" M BSP	500 x Ø54	5	1,59	l/min			46,0	48,0	50,0	54,0	60,0
					m.c.a			0,70	0,73	0,75	0,80	0,90
F2612092	G 2" M BSP	645 x Ø54	5	1,85	l/min			48,0	51,0	54,0	60,0	66,0
					m.c.a			0,80	0,83	0,87	0,94	1,00

Más información en [www.saferain.com](http://www.saferain.com) | Further information at [www.saferain.com](http://www.saferain.com)

# Compact crystal jet/ Chorro de cristal compacto

The COMPACT CRYSTAL JET is a nozzle that develops a water jet in a laminar regime, giving the water a unique appearance, producing a striking visual aspect for the viewer. Due to its compact design and reduced dimensions, it is easier to use in any installation that combined with its low splashing and low noise level, it makes it ideal for small gardens, and a complementary element of any fountain.

El Chorro de cristal compacto es una boquilla que desarrolla un chorro de agua en régimen laminar, dándole al agua un aspecto único, produciendo un aspecto visual impactante para el espectador. Debido a su diseño compacto y dimensiones reducidas, se facilita su empleo en cualquier instalación que combinado con su baja salpicadura y bajo nivel de ruido, lo hace ideal para pequeños jardines, y un elemento complementario de cualquier fuente.

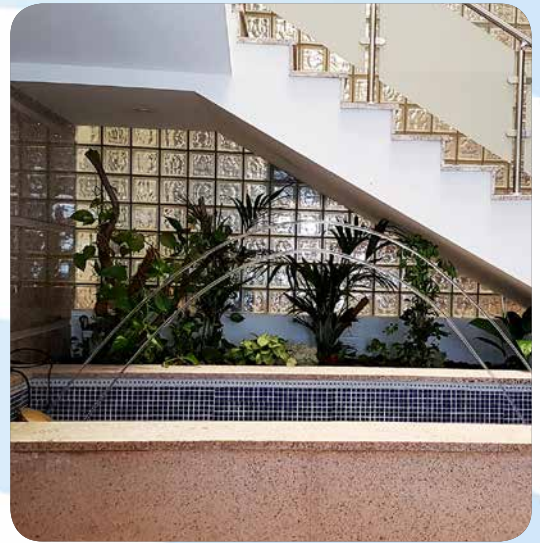

Nozzles/  
Boquillas

**Brass + Stainless steel**  
**Latón + Acero Inox.**



Water appearance/ Aspecto del agua Clear/ Cristalino  
Wind resistance/ Resistencia al viento ★★★★★  
Splash/ Salpicadura ★★★★★  
Sound level/ Nivel de sonido ★★★★★  
Visibility/ Visibilidad ★★★★★

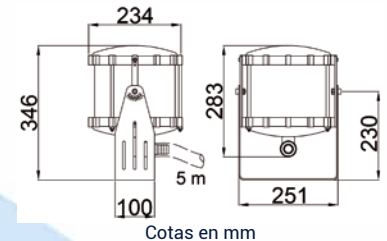
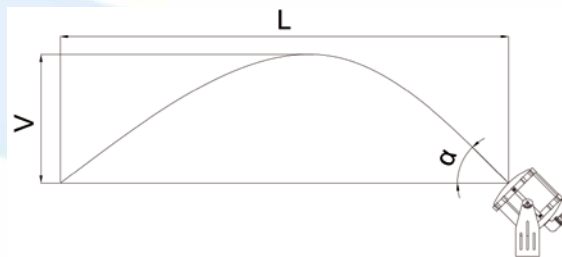

Dimensions/ Dimensiones				Performance/ Rendimiento					
Reference/ Referencia	Connection/ Conexión BSP-NPT	Outlet/ Salida (mm)	Weight/ Peso (kg)	Jet angle/ Ángulo de salida (α)	Horizontal range/ Alcance horizontal (m) L	1	2	3	4
F4321001	G1" F/H(*)	Ø14	17,0	30°	I/min	18,00	25,00	30,00	34,00
					m.c.a	0,90	1,60	2,40	3,00
					Height (m) V	0,19	0,32	0,47	0,56
				45°	I/min	17,20	23,50	30,00	35,00
					m.c.a	0,90	1,50	2,20	2,80
					Height (m) V	0,33	0,54	0,80	1,06
				60°	I/min	19,00	26,00	32,00	36,60
					m.c.a	1,00	1,80	2,40	3,20
					Height (m) V	0,53	0,97	1,38	1,83
				75°	I/min	24,40	35,50		
					m.c.a	1,60	3,00		
					Height (m) V	1,10	2,00		

(\*) Included 5 meter of hose/ Incluye 5 metros de manguera

Safe Rain recommended use of Pump F6524908, it is not included in kit F4321001/ Safe Rain aconseja el uso de la electrobomba F6524908 que no se incluye en el kit F4321001

Further information at [www.saferain.com](http://www.saferain.com) | Más información en [www.saferain.com](http://www.saferain.com)



# Compact rainbow jet/ Arcoiris compacto

The COMPACT RAINBOW JET is a nozzle that develops an illuminated laminar water jet, giving the water a unique aspect, producing a striking visual aspect for the viewer. In its compact design we have incorporated a high power RGBW LED that dramatically illuminates the water parabola in its entirety. Due to its compact design and small dimensions, it is easy to use in any installation that combined with its low splash and low level of noise, makes it ideal for small gardens, and a complementary element of any source.

El Arcoiris Compacto es una boquilla que desarrolla un chorro de agua laminar iluminado, dándole al agua un aspecto único, produciendo un aspecto visual impactante para el espectador. En su compacto diseño hemos incorporado un LED RGBW de alta potencia que permite iluminar espectacularmente la parábola de agua en su totalidad. Debido a su diseño compacto y dimensiones reducidas, se facilita su empleo en cualquier instalación que combinado con su baja salpicadura y bajo nivel de ruido, lo hace ideal para pequeños jardines, y un elemento complementario de cualquier fuente.



Water appearance/ Aspecto del agua **Clear/ Cristalino**  
 Wind resistance/ Resistencia al viento ★★★★★  
 Splash/ Salpicadura ★★★★★  
 Sound level/ Nivel de sonido ★★★★★  
 Visibility/ Visibilidad ★★★★★

**Brass + Stainless steel**  
**Latón + Acero Inox.**

**AISI 304** **ON STOCK**  
**RGBW** **LED**

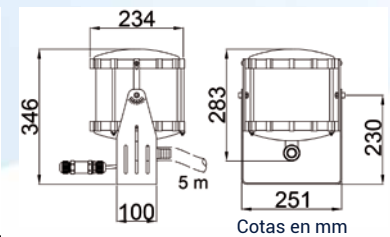
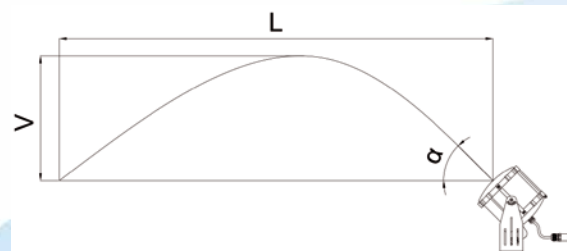

\* Rainbow Jet use is recommended with low environmental light. Maximum 180 lx/ Se recomienda el uso del Rainbow Jet con baja luminosidad ambiental. Máximo 180 lx.

Dimensions/ Dimensiones							Performance/ Rendimiento						
Reference/ Referencia	Connection/ Conexión BSP-NPT	Outlet/ Salida (mm)	Weight/ Peso (kg)	Power/ Potencia	Voltage/ Voltaje	Elec. Connec- tion/ Conexión eléctrica	Jet angle/ Ángulo de salida (α)	Horizontal range/ Alcance horizontal (m) L	1	2	3	4	
F4322002	G1" F/H(*)	Ø14	17,0	10W	24V DC	0,5m cable with IP68 connector H05RR-F H05RN-F H07RR-F H07RN-F Ø10 - Ø13	30°	I/min	18,00	25,00	30,00	34,00	
								m.c.a	0,90	1,60	2,40	3,00	
								Height (m) V	0,19	0,32	0,47	0,56	
							45°	I/min	17,20	23,50	30,00	35,00	
								m.c.a	0,90	1,50	2,20	2,80	
								Height (m) V	0,33	0,54	0,80	1,06	
							60°	I/min	19,00	26,00	32,00	36,60	
								m.c.a	1,00	1,80	2,40	3,20	
								Height (m) V	0,53	0,97	1,38	1,83	
							75°	I/min	24,40	35,50			
								m.c.a	1,60	3,00			
								Height (m) V	1,10	2,00			

(\*) Included 5 meter of hose/  
 Incluye 5 metros de manguera

For the lighting control it is necessary the controller RGBW F6325356/ Para el control de la iluminación es necesario el controlador RGBW F6325356

Safe Rain recommended use of Pump F6524908, it is not included in kit F4322002/ Safe Rain aconseja el uso de la electrobomba F6524908 que no se incluye en el kit F4322002

# Frothy fountain jets/ Chorros de agua espumosos

Snowy jet/ Chorro de nieve Pag 52

Foamy column jet/ Columna de espuma Pag 53

Cascade jet/ Cascada Pag 54

Joint cascade jet/ Cascada mixta Pag 55

Geyser jet/ Géiser Pag 56

Snowy fir jet/ Abeto de nieve Pag 57



The aim of frothy fountain nozzles is to generate **white or frothy fountain jets** in water feature fountains. In order to achieve this, turbulent flow has to be generated inside the jet pipe, which can be achieved in two ways:

1. By the outgoing jet drawing a column of water from the basin: for this, it has to remain immersed in water (cascade)..
2. By mixing air and water via the Venturi effect (snowy jet). Both features (geyser jet and foam cascade) can be combined.

El objetivo de este tipo de boquillas es el de generar **chorros de agua "blancos o espumosos"** en las fuentes ornamentales. Para ello, se hace necesario generar un régimen turbulento dentro de la tobera y esto se consigue de dos maneras:

1. El chorro de salida arrastre una columna de agua del vaso, para lo cual debe quedar sumergida (Cascada).
2. Mezclar el aire y agua por efecto venturi (Chorro de nieve). Se pueden combinar ambos efectos (Geiser, Abeto de nieve).

# Snowy jet/ Chorro de Nieve

This is one of the most widely used nozzles in architectural fountains, due to its easy installation and attractive spray pattern. The proper functioning of this nozzle is **not water level dependent** and because of its inner workings, mix a lot of air with water, obtaining a particularly attractive sparkling effect when lit up at night. It is made from different materials for greater versatility (brass, plastic and stainless steel, brass and stainless steel).

Esta es una de las boquillas más utilizadas en fuentes ornamentales, por su sencillez de instalación y su atractivo efecto acuático. El correcto funcionamiento de esta tobera **no depende del nivel del agua** y debido a su funcionamiento interno, mezcla una gran cantidad de aire con agua, obteniendo un efecto burbujeante especialmente atractivo cuando es iluminado por la noche. Se fabrica en distintos materiales para conseguir una mayor versatilidad (latón, plástico y acero inoxidable, latón y acero inoxidable).



## Brass + Stainless steel/ Latón + Acero Inox.



- Water appearance/ Aspecto del agua: Foamy/ Espumoso ★★★★★
- Wind resistance/ Resistencia al viento: ★★★★★
- Splash/ Salpicadura: ★★★★★
- Sound level/ Nivel de sonido: ★★★★★
- Visibility/ Visibilidad: ★★★★★



Dimensions/ Dimensiones							Performance/ Rendimiento							
Reference/ Referencia	Connection/ Conexión A	Adaptor/ Adaptador BSP-NPT	Outlet/ Salida (mm) B	Length/ Long. C x D (mm)	Material/ Material	Weight/ Peso (kg)	Height/ Altura (m)	0,5	1,0	2,0	2,5	3,0	4,0	6,0
F2391208	G 1/2" M BSP-NPT		Ø24	76,5x Ø54	Brass/ Latón	0,64	l/min	44	74	98				
							m.c.a	1,5	3,8	5,7				
F2401007	G 1" M BSP	11793 1" F-F/ H-H	Ø32	132x Ø53	Plastic + AISI 304/ Plástico + AISI 304	0,44	l/min	49	71	97	107			
	m.c.a						1,0	2,1	4,4	5,4				
F2401018	G 1" M BSP				Plastic + AISI 316/ Plástico + AISI 316	0,44	l/min	49	71	97	107			
							m.c.a	1,0	2,1	4,4	5,4			
F2391006	G 1" M BSP-NPT		Ø50	140x Ø92	Brass/ Latón	2,34	l/min	100	140	190	220	240		
							m.c.a	1,5	3,2	6,0	7,2	8,9		
F2401503	G 1 1/2" M BSP-NPT			201x Ø84	Brass + Stainless steel AISI 304/ Latón + Acero Inox AISI 304	1,40	l/min	88	123	175	194	212	230	
			m.c.a				1,1	2,1	3,8	4,7	5,7	7,3		
F2402008	G 2" M BSP-NPT		Ø75	232x Ø115		2,30	l/min	217	308	415	472	516	605	755
							m.c.a	0,8	1,7	3,1	4,1	5,0	6,7	10,2



# Foamy Column jet/ Columna de Espuma

This nozzle is, itself, a spray ring on which between 24 and 90 (depending on size) 6 mm jet nozzles are fitted to **produce a larger diameter rising column of water** but without the high flow that a continuous jet of the same diameter outlet would require. The jet nozzle outlet has to remain above the level of the water pond. The name itself indicates the foamy appearance it produces, which is achieved by adding several small jets. It is **highly suitable for large outdoor water feature fountains**.

Esta boquilla es en si misma un colector en el cual se incorporan entre 24 y 90 (según tamaño) chorros de lanza de 6mm para conseguir una **columna ascendente de agua de gran diámetro** pero sin el gran caudal que necesitaría un chorro de dicho diámetro continuo. La salida de las toberas de lanza debe quedar por encima del nivel de agua del vaso. Es muy adecuada para **grandes fuentes ornamentales de exterior**.



Nozzles/  
Boquillas

CHROME

METEOR

Brass/ Latón

Water appearance/ Aspecto del agua

Wind resistance/ Resistencia al viento

Splash/ Salpicadura

Sound level/ Nivel de sonido

Visibility/ Visibilidad

Foamy/ Espumoso

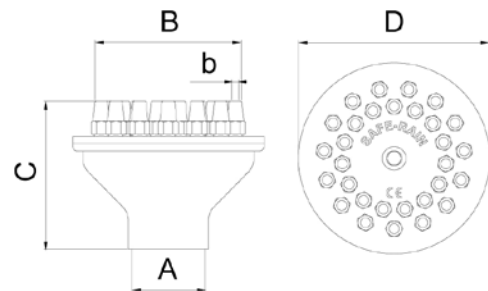

Dimensions/ Dimensiones							Performance/ Rendimiento									
Reference/ Referencia	Connection/ Conexión A BSP	Outlet/ Salida B (mm)	Length/ Long. C (mm)	Diameter/ Diámetro D (mm)	Jets number/ Nº de chorros b	Weight/ Peso (kg)	Height/ Altura (m)	0,5	1,0	2,0	3,0	4,0	5,0	6,0	7,0	8,0
F2431001	G 1" F/H	Ø66	64	Ø84	24x Ø6mm	1,03	l/min	100	120	154						
							m.c.a	1,0	1,8	3,2						
F2431315	G 1¼" F/H	Ø90	88	Ø114	30x Ø6mm	2,00	l/min	195	258	355	430	492				
							m.c.a	1,3	2,5	4,6	6,3	7,6				
F2432518	G 2½" F/H	Ø210	150	Ø258	72x Ø6mm	7,80	l/min	468	620	850	1032	1181	1304	1385		
							m.c.a	1,5	2,7	4,5	6,1	7,3	8,3	9,1		
F2433003	G 3" F/H	Ø250	183	Ø312	90x Ø6mm	12,50	l/min	585	775	1060	1290	1465	1625	1800	1900	1980
							m.c.a	1,3	2,5	4,6	6,3	7,6	8,5	9,0	9,8	10,1

Más información en [www.saferain.com](http://www.saferain.com) | Further information at [www.saferain.com](http://www.saferain.com)

# Cascade jet/ Cascada

This nozzle, made of brass, is one of the most widely used in architectural fountains. If it is installed with the level of water given by the manufacturer, it generates a very attractive cone of sparkling water. The water coming out of the cascade jet nozzle draws a column of water from the fountain pond, which produces a great deal of turbulence.

Esta boquilla, fabricada en latón, es una de las más utilizadas en fuentes ornamentales. Si se instala según el nivel de agua indicado y genera un cono de agua burbujeante de gran atractivo. El agua que sale de la tobera arrastra en su salida a una columna de agua del vaso de la fuente, lo que provoca un régimen totalmente turbulento.



Nozzles/  
Boquillas

CHROME

IN STOCK

Brass/ Latón



Water level dependent nozzle/ Boquilla dependiente nivel agua

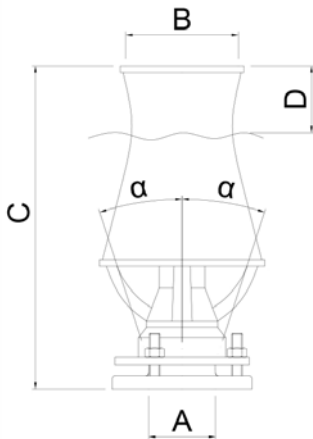

Water appearance/ Aspecto del agua  
Wind resistance/ Resistencia al viento  
Splash/ Salpicadura  
Sound level/ Nivel de sonido  
Visibility/ Visibilidad

Foamy/ Espumoso  
★★★★★  
★★★★☆  
★★★★☆  
★★★★★

Dimensions/ Dimensiones								Performance/ Rendimiento									
Reference/ Referencia	Connection/ Conexión A BSP	Outlet/ Salida (mm) B	Length/ Long. (mm) C	Water level/ Nivel agua D (mm)	Straighteners /Centradores	Angle/ Angulo (α)	Weight/ Peso (kg)	Height/ Altura (m)	0,5	1,0	1,5	2,0	3,0	4,0	5,0	6,0	7,0
F2451205	G 1/2" M	Ø35	145,5	20	✓	31°	0,43	l/min	15	21	27	31					
								m.c.a	6,4	12,0	17,5	23,0					
F2451003	G 1" M	Ø50	201	30	✓	16°	0,95	l/min	32	45	55	63	80	91			
								m.c.a	2,6	4,9	7,0	9,0	13,6	17,8			
F2451508	G 1½" F/H	Ø82	250	50	✗	10°	3,30	l/min	52	82	104	120	145	164	177	185	190
								m.c.a	3,4	5,5	5,3	7,2	11,0	14,6	18,5	22,3	26,0

Más información en [www.saferain.com](http://www.saferain.com) | Further information at [www.saferain.com](http://www.saferain.com)

# Joint cascade/ Cascada mixta

This nozzle gets the same aquatic effect than the Cascade jet but is made of brass and stainless steel. Just as the model made of brass is widely used in ornamental fountains.

Esta boquilla consigue el mismo efecto acuático que la Cascada pero está fabricada en latón y acero inoxidable. Al igual que el modelo fabricado en latón es ampliamente usada en las fuentes ornamentales.

**Brass + Stainless steel/ Latón + Acero Inox.**



Water level dependent nozzle/ Boquilla dependiente nivel agua



Nozzles/  
Boquillas

Water appearance/ Aspecto del agua Foamy/ Espumoso  
 Wind resistance/ Resistencia al viento ★★★★★  
 Splash/ Salpicadura ★★★★★  
 Sound level/ Nivel de sonido ★★★★★  
 Visibility/ Visibilidad ★★★★★

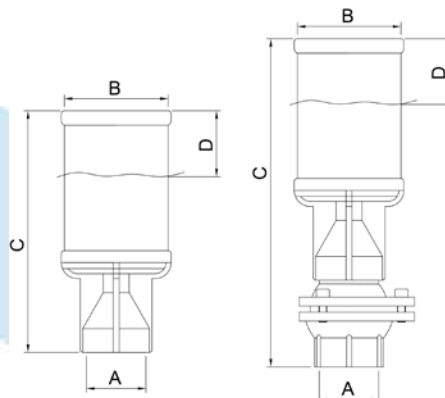

Dimensions/ Dimensiones										Performance/ Rendimiento									
Reference/ Referencia	With ball joint/ Con rótula bola	Connection/ Conexión A	Adaptor/ Adaptador BSP-NPT	Outlet/ Salida B (mm)	Length/ Long. C (mm)	Water level/ Nivel agua D (mm)	Weight / Peso (kg)	Angle/ Ángulo (α)	Height/ Altura (m)	1	2	3	4	5	6	10	12	14	
F2462038		G 2" F/H BSP-NPT		Ø100	242	61	1,9		l/min	140	180	210	240	263	285				
F2462051	✓				330		3,9	23°	m.c.a	2,40	4,10	5,90	7,60	9,50	11,60				
F2462534		G 2½" F/H BSP	F7380257 2½" M-M	Ø125	307	77	3,0		l/min	220	270	317	360	396	430	550			
F2462556	✓				410		6,5	20°	m.c.a	2,70	4,40	6,14	8,00	10,00	12,30	21,60			
F2463038		G 3" F/H BSP	F7380303 3" M-M	Ø150	360	90	4,5		l/min	314	410	496	570	628	680	900	1010	1130	
F2463052	✓				480		9,5	20°	m.c.a	2,80	5,00	7,10	9,30	11,50	14,00	23,00	28,00	32,50	



# Geyser jet/ Géiser

The geyser jet nozzle produces an output fountain jet that combines a mixture of water from the pump, water from the pond and air. The end jet pattern is a column of white water, created by mixing air and water together. They are equipped with tilt correctors to prevent unwanted jet inclination. The smaller sized geyser jet nozzles (1/2" and 1") are made of 100% cast and machined brass, while the larger sizes (1 1/2", 2, 2 1/2" and 3") are a mixture of stainless steel and brass.

En estas boquillas el chorro de salida es una mezcla de agua de la bomba, agua del vaso y aire. El aspecto final del chorro es un cilindro de agua blanca, consecuencia de la mezcla aire y agua. Están provistas de correctores de inclinación para evitar inclinaciones no deseadas. En las medidas pequeñas (1/2" y 1") las toberas son enteramente de latón fundido y mecanizado mientras que en las de mayor medida (1 1/2", 2, 2 1/2" y 3) son mezcla de acero inoxidable y latón.



Nozzles/  
Boquillas

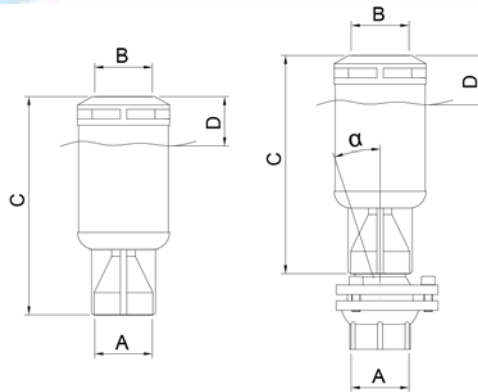

Water appearance/ Aspecto del agua  
Wind resistance/ Resistencia al viento  
Splash/ Salpicadura  
Sound level/ Nivel de sonido  
Visibility/ Visibilidad

Foamy/ Espumoso  
★★★★☆  
★★★★☆  
★★★★☆  
★★★★☆

**AINI 304**

**ON STOCK**



Water level dependent nozzle/  
Boquilla dependiente nivel agua

**Brass + Stainless steel/  
Latón + Acero Inox.**

Dimensions/ Dimensiones									Performance/ Rendimiento												
Reference/ Referencia	With ball joint/ Con rótula bola	Connection/ Conexión A	Adaptor/ Adaptador BSP-NPT	Outlet/ Salida B (mm)	Length/ Long. C (mm)	Water level/ Nivel agua D (mm)	Weight/ Peso (kg)	Angle/ Ángulo (α)	Height/ Altura (m)	0,5	1,0	2,0	3,0	4,0	6,0	8,0	12,0	16,0	20,0	30,0	
F2371206	✓	G 1/2" M BSP-NPT		Ø16	135	30	0,40	25°	I/min	11,1	15,0	21,0	22,5								
									m.c.a	2,00	3,25	5,25	7,25								
F2371004	✓	G 1" M BSP	5876 1" F-F/ H-H	Ø24	203	50	1,13	24°	I/min	25,0	33,5	44,0	54,0	62,0	73,0						
									m.c.a	1,2	2,4	4,0	5,8	7,4	10,8						
F2381501		G 1 1/2" F/H BSP-NPT		Ø48	204	45	2,00	23°	I/min	68,0	83,0	111,0	128,0	146,0	170,0	193,0					
F2381512	✓				274				3,40	m.c.a	1,7	2,6	4,4	6,2	7,8	11	14,5				
F2382006		G 2" F/H BSP-NPT		Ø60,5	252	65	3,00	23°	I/min	93,0	115,0	146,0	178,0	203,0	238,0	274,0	332,0				
F2382017	✓				339				5,00	m.c.a	1,7	2,5	4,1	5,8	7,5	10,8	14,2	20,9			
F2382502		G 2 1/2" F/H BSP	F7380257 2 1/2" M-M	Ø80	336	75	5,00	30°	I/min	166,0	212,0	267,0	325,0	368,0	423,0	486,0	577,0	675,0	753,0		
F2382513	✓				438				8,00	m.c.a	1,6	2,5	4,2	6,3	7,9	10,8	14,3	21,0	27,7	34,4	
F2383007		G 3" F/H BSP	F7380303 3" M-M	Ø100	414	90	8,50	30°	I/min		320,0	380,0	458,0	522,0	615,0	658,0	843,0	968,0	1080,0	1320,0	
F2383018	✓				534				13,20	m.c.a		2,2	3,3	5,0	6,9	9,2	10,9	17,8	23,5	29,2	44,0

Más información en [www.saferain.com](http://www.saferain.com) | Further information at [www.saferain.com](http://www.saferain.com)

# Snowy Fir jet/ Abeto de Nieve

This nozzle produces a water cone that is particularly beautiful when lit up at night. Combining the effects of suctioning air and drawing water from the pond, thus producing bubbles of water that look like floating beads when lit at night. The installation height of the nozzle, which is fully immersed except for the air-suction pipe, must be strictly complied with.

Esta boquilla genera un cono de agua, especialmente bonito cuando se ilumina por la noche. Combinando los efectos de succión de aire y arrastre de agua del vaso se generan unos borbotones de agua que iluminados por la noche parecen perlas flotantes. Se requiere ser estricto en el nivel de instalación de la tobera, que va totalmente sumergida a excepción del tubo por el cual se succiona aire.



Nozzles/  
Boquillas

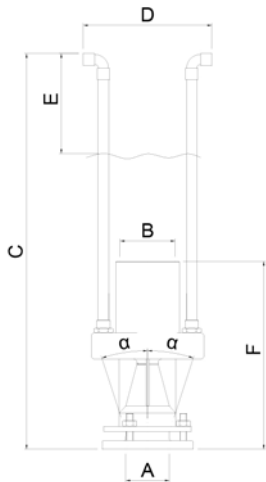

Water appearance/ Aspecto del agua Foamy/ Espumoso  
 Wind resistance/ Resistencia al viento ★★★★★  
 Splash/ Salpicadura ★★★★★  
 Sound level/ Nivel de sonido ★★★★★  
 Visibility/ Visibilidad ★★★★★

CHROME

ON STOCK



Water level dependent nozzle/  
Boquilla dependiente nivel agua

Brass/ Latón

Dimensions/ Dimensiones								Performance/ Rendimiento											
Reference/ Referencia	Connection/ Conexión A BSP	Outlet/ Salida (mm) B	Length/ Long. (mm) C x D	Water level/ Nivel agua (mm) E	Length/ Long. (mm) F	Angle/ Ángulo (α)	Weight/ Peso (kg)	Height/ Altura (m)	0,5	1,0	1,5	2,0	3,0	5,0	7,0	9,0	12,0	14,0	
F2491209	G 1/2" M	Ø25	177x	55	86	15°	0,37	l/min	19	25	28								
			66					m.c.a	6,0	9,0	11,0								
F2491007	G 1" M	Ø50	316x	100	156	19°	0,96	l/min	86	104	118	130	148						
			94					m.c.a	7,6	15,0	20,9	26,5	35,0						
F2491503	G 1½" F/H	Ø65	453x	115	215	8°	2,90	l/min	121	175	212	232	255	275					
			147					m.c.a	10,0	20,0	26,5	34,0	44,0	99,0					
F2492008	G 2" F/H	Ø75	463x	125	213	8°	4,70	l/min	148	205	238	260	290	325	340	347			
			155					m.c.a	8,0	17,0	25,0	31,0	43,0	61,0	75,0	85,0			
F2492504	G 2½" F/H	Ø107	585x	150	322	8°	10,8	l/min	248	350	425	495	603	780	920	1050	1200	1298	
			199					m.c.a	6,0	11,0	15,0	18,5	25,0	35,0	42,0	49,0	56,0	58,0	

Más información en [www.saferain.com](http://www.saferain.com) | Further information at [www.saferain.com](http://www.saferain.com)

# Rotatory nozzles/ Boquillas dinámicas

Cyclone/ Ciclón Pag 59

Twister/ Tornado Pag 60

Hibiscus/ Hibiscus Pag 61

Dancing/ Dancing Pag 62



**T**hanks to rotating nozzles - also known as dancing or dynamic nozzles - we are able to add **dynamism to the water and obtain attractive water features** that are suitable for use in both **cybernetic fountains and musical fountains**, in which the rhythm of the music merges with the movement of the water.

It is possible to use these types of fountain nozzles to bring the "water to life", which is a particularly attractive effect at night, allowing the water to fill any architectural space when it is lit up.

Therefore, we believe that they will not leave anyone unimpressed, and that you will be able to use them in decorative indoor water features, or as a feature in any urban space.

**G**racias a las boquillas danzarinas -también conocidas como boquillas dinámicas - conseguimos imprimirle **dinamismo al agua y obtener atractivos juegos acuáticos** idóneos para ser utilizados tanto en **fuentes cibernéticas como en fuentes musicales** donde el ritmo de la música se funde con el movimiento del agua.

Con este tipo de boquillas conseguimos darle "vida al agua" obteniendo un efecto especialmente atractivo por la noche, donde iluminadas consiguen llenar cualquier espacio arquitectónico.

Creemos por tanto que no te dejarán indiferente y sabrás emplearlas en fuentes decorativas de interior o bien para completar cualquier espacio urbano.



# Cyclone/ Ciclón

Rotating nozzle based on the exclusive low friction turning system developed by SAFE RAIN, thanks to the arrangement of its 5 nozzles of 8 mm output generates very consistent rotary helical figures. Essential to make any fountain special by incorporating these elegant and striking figures in movement, which accept a slight adjustment of their conicity for a better adaptation to the requirements of each fountain.

Boquilla rotativa basada en el exclusivo sistema de giro de bajo rozamiento desarrollado por SAFE RAIN, que gracias a la disposición de sus 5 boquillas de 8 mm de salida genera figuras helicoidales rotativas muy consistentes. Imprescindibles para hacer especial cualquier fuente al incorporar estas elegantes y llamativas figuras en movimiento, las cuales aceptan un ligero ajuste de su conicidad para una mejor adaptación a los requerimientos de cada fuente.



Nozzles/  
Boquillas

Brass + Stainless steel/ Latón + Acero Inox.



✔ Straighteners/ Centradores

Water appearance/ Aspecto del agua Clear/ Cristalino ★★★★★  
 Wind resistance/ Resistencia al viento ★★★★★  
 Splash/ Salpicadura ★★★★★  
 Sound level/ Nivel de sonido ★★★★★  
 Visibility/ Visibilidad ★★★★★

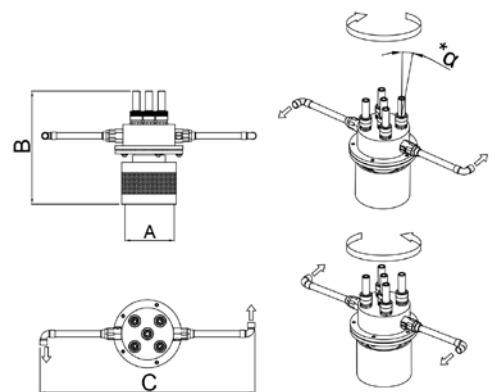
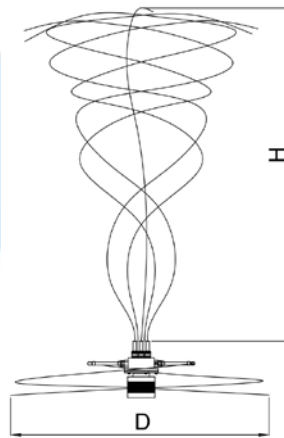

Dimensions/ Dimensiones								Performance/ Rendimiento				
Reference/ Referencia	Connection/ Conexión A	Connection NPT/ Conexión NPT	Lenght/ Long. (mm) BXC	Inclination angle/ Ángulo de inclinación $\alpha^\circ$	Jets number/ Nº de chorros	Outlet/ Salida (mm)	Weight/ Peso (Kg)	Height/ Altura (m) H	1,5	2,0	2,5	3,0
F2863001	G3" BSP F/ H	F7380303 NIPPLE/ MACHÓN 3" BSP/ NPT M/M	Ø220 X 418	* Max. 12°	5	Ø8	5,8	L/min	110	125	145	165
								m.c.a	1,8	2,3	2,9	3,5
								Diam. (m) D	2,4	2,5	3,1	3,8

-Turn clockwise or counterclockwise/ Giro a derechas o izquierdas.

\* -Tilt the angle " $\alpha$ " 6° of the 4 external lances as indicated in the diagram to achieve the specified performance/ Incline el ángulo " $\alpha$ " 6° de las 4 lanzas exteriores como se indica en el esquema para lograr el comportamiento especificado.

Más información en [www.saferain.com](http://www.saferain.com) | Further information at [www.saferain.com](http://www.saferain.com)

# Twister/ Tornado

Rotary nozzles that achieves amazing Effects, big amount of water in movement. Through the exclusive low friction swivel system developed by SAFE RAIN, get the rotation using only water pressure allowing both the vertical installation generating a dynamic sun effect essential in all musical fountains, or elevated horizontally generating a funny parasol ideal for children's play areas.

Boquilla rotativa que logra espectaculares efectos, grandes volúmenes de agua en movimiento. Mediante el exclusivo sistema de giro de bajo rozamiento desarrollado por SAFE RAIN logra la rotación con sólo la presión del agua permitiendo tanto la instalación vertical generando un efecto sol dinámico imprescindible en todas las fuentes musicales, o en horizontal elevado dando lugar a un gracioso parasol ideal para aéreas de juegos infantiles.



Water appearance/ Aspecto del agua  
Wind resistance/ Resistencia al viento  
Splash/ Salpicadura  
Sound level/ Nivel de sonido  
Visibility/ Visibilidad

Clear/ Cristalino  
★★★★★  
★★★★★  
★★★★★  
★★★★★

Stainless steel + Brass/ Acero Inox. + Latón

AI SI 304

UNISTOCK

✔ Straighteners/ Centradores

Nozzles/  
Boquillas

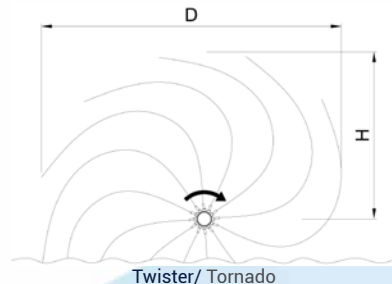

Twister/ Tornado

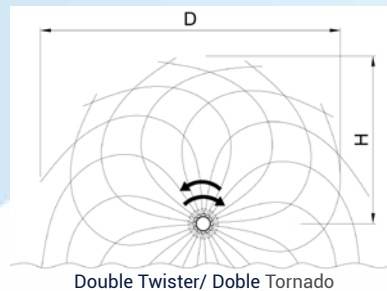
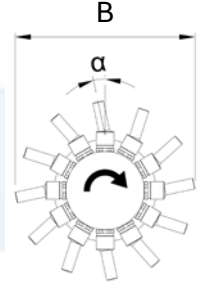
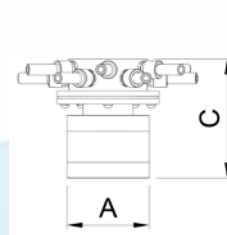

Double Twister/ Doble Tornado

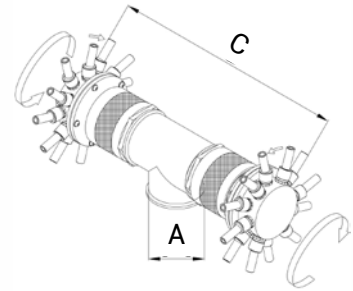

Dimensions/ Dimensiones								Performance/ Rendimiento					
Reference/ Referencia	Connection/ Conexión A BSP	Adaptor/ Adaptador BSP-NPT	Length/ Long. (mm) B x C	Inclination/ Inclinación	Jets number/ Nº chorros	Outlet/ Salida (mm)	Weight/ Peso (Kg)	Pressure/ Presión (m.c.a)	3,5	4,0	5,0	6,0(*)	7,0(*)
F2833007	G3" F/H	F7380303 3" M-M	Ø230 x 125	Max.	12	Ø8	5,7	Height/ Altura (m) H	2,25	2,50	3,50	4,0	4,75
Diam. (m)								9,0	12,0	14,0	16,0	18,0	
Flow l/min								265	280	315	345	375	
F2833029	G3" F/H	F7380303 3" M-M	Ø230 x 480	Max.	24	Ø8	12	Height/ Altura (m) H	2,75	3,00	3,50	4,0	4,30
Diam. (m)								11,7	12,4	14,2	16,0	17,2	
Flow l/min								530	550	614	670	720	

- Rotation right and left / Giro a derecha e izquierda

- Lances Jet must have a maximum inclination, in order to met data table values / Las lanzas deben tener la inclinación máxima para que se cumplan los datos de la tabla. (\*) From 6 m.c.a. and above, the rotational speed of the nozzle is so high that the visual rotational effects is lost / A partir de 6 m.c.a. La velocidad de giro de la tobera es elevada y se pierde el efecto de rotación del chorro.

# Hibiscus/ Hibiscus

These perfectly formed, revolving drops of water mean, that you don't have to go to Central Park to relax, as this union of little falling drops, forming a flower shape, gives you the same sensation of wellbeing.

The greater the pressure at the outlet of this nozzle, the faster the rotation speed and, therefore, the higher the height of the cone. This cone is made up of hundreds of spinning drops which, when illuminated, form authentic pearls of color. It is wonderful at night.

Una revolución de gotas perfectamente formadas, que hace que no sean necesarios los jardines de la Alhambra para que esa unión de pequeñas gotas que caen, formando una flor, nos transmitan la misma sensación de bienestar.

Cuanto mayor es la presión en la toma de esta boquilla, mayor será la velocidad de giro y, por tanto, mayor la altura del cono. Este cono está formado por cientos de gotas girando que, en el caso de llevar iluminación, formarían auténticas perlas de color. Una maravilla en la noche.



- Water appearance/ Aspecto del agua: Clear/ Cristalino
- Wind resistance/ Resistencia al viento: ★★☆☆☆
- Splash/ Salpicadura: ★☆☆☆☆
- Sound level/ Nivel de sonido: ★☆☆☆☆
- Visibility/ Visibilidad: ★★★★★

Nozzles/  
Boquillas

PVC + Stainless steel/ PVC + Acero Inox.

AISI 304

ONETECH

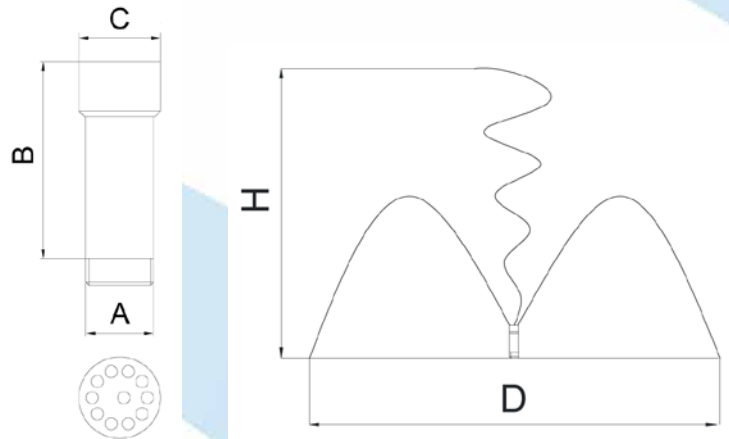

Dimensions/ Dimensiones				Performance/ Rendimiento					
Reference/ Referencia	Connection/ Conexión A BSP-NPT	Length/ Long. (mm) B x C	Weight/ Peso (kg)	Middle jet height/ Altura chorro central (m) H	0,5	1,0	1,5	2,0	2,5
F2813411	G ¾" M	94x Ø31	0,30	Diameter/ Diametro (m) D	0,5	1,0	1,3	1,5	
				l/min	10	22	28	37	
				m.c.a	0,4	1,2	1,8	2,4	
F2811014	G 1" M	97x Ø40	0,30	Diameter/ Diametro (m) D	0,5	1,0	2	2,5	
				l/min	26	45	59	71	
				m.c.a	0,4	1,2	2,0	3,2	
F2811519	G 1½" M	125x Ø61	0,51	Diameter/ Diametro (m) D	1,5	2,5	3,0	4,0	4,5
				l/min	48	76	92	110	128
				m.c.a	0,4	1,2	1,8	2,4	3,2

Further information at [www.saferain.com](http://www.saferain.com) | Más información en [www.saferain.com](http://www.saferain.com)



# Dancing/ Dancing

As with the "Hibiscus" fountain nozzle, the theory behind the operation of this rotating nozzle is based on the waterwheel. Using only water pressure, a **continuous effect of movement is created without additional mechanical or electrical devices**. No movement is necessary to generate this watery swaying motion. A swaying motion that brings to mind mesmerizing Arab belly dancing.

Esta boquilla giratoria basa su funcionamiento, al igual que la boquilla "Hibiscus", en el molinete hidráulico. Con sólo la presión del agua se genera un **movimiento de efecto continuo sin dispositivos mecánicos ni eléctricos adicionales**. No hay desplazamiento para generar ese contoneo del agua. Contoneo que recuerda a la envolvente danza árabe del vientre.



**Brass + Stainless steel/ Latón + Acero Inox.**



✔ Straighteners/ Centradores

Water appearance/ Aspecto del agua Clear/ Cristalino  
 Wind resistance/ Resistencia al viento ★★☆☆☆☆  
 Splash/ Salpicadura ★★☆☆☆☆  
 Sound level/ Nivel de sonido ★★☆☆☆☆  
 Visibility/ Visibilidad ★★★★★★

Nozzles/  
Boquillas

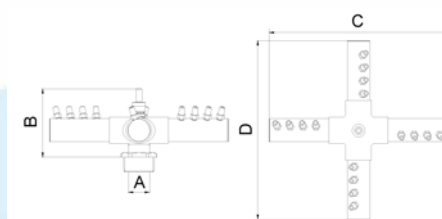
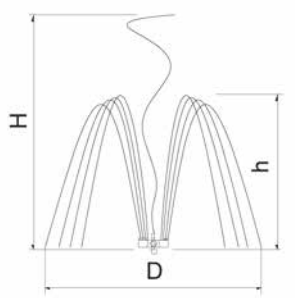

Dimensions/ Dimensiones						Performance/ Rendimiento													
Reference/ Referencia	Connection/ Conexión A	Length/ Long. (mm) B	Length/ Long. (mm) C x D	Jets number/ Nº chorros	Weight/ Peso (kg)	Pressure/ Presión (m.c.a)	2,5	3,0	3,5	4,0	4,5	5,0	5,5	6,5	7,0	8,0	9,0		
							F2823412	¾" M NPT/ BSP	79	128x128	4+1	0,40	Height (m)	H	1,50	2,00	2,25	2,50	
						h	1,25	1,50	1,75	1,75									
						Diam. (m)		2,2	2,3	2,7	3,2								
						Flow	l/min	25	28	30	32								
						m³/h	1,50	1,68	1,98	1,92									
F2821511	1½" M NPT/ BSP	106	280x280	16+1	1,62	Height (m)	H			3,25	3,50	4,00	4,25	4,50					
						h			2,25	2,50	2,75	3,00	3,25						
						Diam. (m)			2,8	4,0	4,5	5,0	5,3						
						Flow	l/min			95	100	105	110	117					
						m³/h			5,7	6,0	6,3	6,6	7,0						
F2822016	2" M NPT/ BSP	148	521x521	24+1	3,80	Height (m)	H							5,00	5,50	6,00	7,00		
						h								3,15	3,50	4,00	4,50		
						Diam. (m)								7,5	8,0	8,5	9,0		
						Flow	l/min							217	225	245	255		
						m³/h								13,02	13,50	14,70	15,30		

# Spray water feature/ Efecto pulverizador

Spraying jet/ Boquilla de pulverización Pag 64

Spraying clouds/ Nubes de pulverización Pag 65



**T**hese spray nozzles are used to generate a volume of **water sprayed with a drop size no greater than 1 mm**. These jets are not used to create great jet heights but rather large volumes in water fountains. When these volumes are created, the lighting manages to totally change the appearance of the fountain during the day and at night, providing two different effects.

**C**on este tipo de boquillas se genera un volumen de **agua pulverizada cuyo tamaño de gota no es mayor de 1 mm**. En este tipo de chorros no se necesita conseguir grandes alturas en las fuentes de agua sino grandes volúmenes. Gracias a este hecho, la iluminación consigue cambiar totalmente el aspecto de la fuente ornamental de día y de noche.

# Spraying jet/ Pulverización

As the name suggests, the aim of this fountain nozzle is to **generate a large volume of water spray or mist**. The aim is not to create great heights but rather large volumes, making it particularly suitable for architectural fountains lit up at night by our underwater spotlights. It should not be installed in open places and, in any case, only at a low height combined with other higher patterns.

Como indica su nombre el objetivo de esta tobera es la de **generar un gran volumen de agua pulverizada o nebulizada**. No se persigue conseguir grandes alturas sino grandes volúmenes, lo que la hace especialmente adecuada para fuentes ornamentales iluminadas en la noche con nuestros focos sumergibles. No hay que instalarla en lugares muy abiertos y en cualquier caso hacerlo a baja altura combinado su efecto con otros principales.



Nozzles/  
Boquillas

CHROME

IN STOCK

Brass/ Latón

Water appearance/ Aspecto del agua

Wind resistance/ Resistencia al viento

Splash/ Salpicadura

Sound level/ Nivel de sonido

Visibility/ Visibilidad

Mist/ Niebla

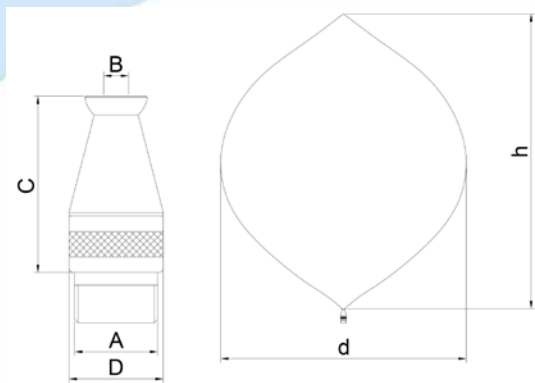

Dimensions/ Dimensiones					Performance/ Rendimiento										
Reference/ Referencia	Connection/ Conexión A BSP/NPT	Outlet/ Salida (mm) B	Length/ Long. (mm) C x D	Weight/ Peso (kg)	Diameter/ Diámetro caída (cm) d	100	150	200	250	300	400	500	600	700	
F2523802	G 3/8" F/H	Ø5	37x 18	0,05	Height/ Altura (m) h	1,00	1,25	1,50							
					l/min	4,50	5,00	5,60							
					m.c.a	4,60	5,80	7,00							
F2521203	G 1/2" M	Ø6	43x 23	0,09	Height/ Altura (m) h			1,00	1,50	2,00					
					l/min			5,60	8,00	9,50					
					m.c.a			3,70	6,40	8,70					
F2523407	G 3/4" M	Ø8	56x 30	0,18	Height/ Altura (m) h				1,00	1,15	1,50	2,00			
					l/min				7,90	8,80	11,50	13,00			
					m.c.a				4,20	4,90	9,20	14,00			
F2521001	G 1" M	Ø10	76x 36	0,28	Height/ Altura (m) h					1,00	1,50	1,85	2,00		
					l/min					11,00	16,00	19,50	21,00		
					m.c.a					4,00	7,60	9,30	13,00		
F2521405	G 1 1/4" M	Ø12	92x 46	0,61	Height/ Altura (m) h						1,00	1,50	1,80	2,00	
					l/min						17,00	21,00	24,00	27,00	
					m.c.a						5,00	7,00	9,00	11,50	



# Spraying clouds/ Nubes de Pulverización

This fountain nozzle is a **water manifold on which several spray nozzle heads are fitted**. The aim is to create a large volume of water spray, which is particularly attractive lit at night in architectural fountains. The type of prevailing wind at the installation site should be taken into account and the water fountain provided with automatic water re-filling, to avoid the risk of the pond running dry.

Esta boquilla es un **colector en el cual se colocan varias toberas de pulverización**. Se persigue crear un gran volumen de agua pulverizada, que resulta especialmente atractivo en fuentes ornamentales iluminadas. Hay que prever el tipo de viento dominante en la zona de instalación y dotar a la fuente de agua de un sistema automático de llenado ya que se corre el riesgo de dejar el vaso vacío.

**CHROME**

**ON STOCK**

Brass/ Latón



Nozzles/  
Boquillas



Water appearance/ Aspecto del agua

Wind resistance/ Resistencia al viento

Splash/ Salpicadura

Sound level/ Nivel de sonido

Visibility/ Visibilidad

Mist/ Niebla

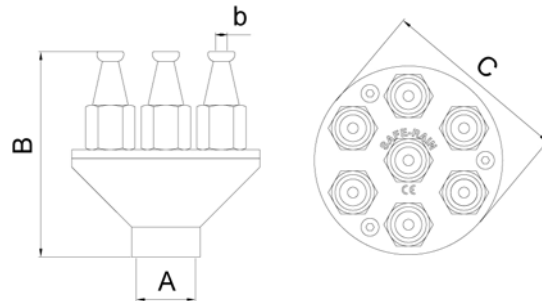

Dimensions/ Dimensiones					Performance/ Rendimiento						
Reference/ Referencia	Connection/ Conexión A BSP	Length/ Long. (mm) Bx C	Outlet/ Salida (mm) b	Weight/ Peso (kg)	Height/ Altura (m)	0,5	1,0	1,5	2,0	2,5	3,0
F3621339	G 1½" F/H	134x Ø132	7x Ø6	2,35	Diam. (m)	1,25	3,25	4,55	5,65	6,55	
					l/min	35	63	102	150	196	
					m.c.a	1,7	2,9	4,9	7,1	9,7	
F3622533	G 2½" F/H	211x Ø255	7x Ø10	10,00	Diam. (m)	1,10	3,10	4,30	5,40	6,20	6,90
					l/min	137	210	252	273	294	308
					m.c.a	1,8	3,1	4,4	6,3	8,7	11,9
F3623038	G 3" F/H	270x Ø312	7x Ø15	22,00	Diam. (m)	2,10	3,30	4,40	5,10	5,60	6,00
					l/min	210	315	392	448	490	532
					m.c.a	2,5	4,4	7,1	10,4	14,7	20,5

Further information at [www.saferain.com](http://www.saferain.com) | Más información en [www.saferain.com](http://www.saferain.com)

# Spherical shapes/ Chorros esféricos

Water sphere/ Esfera de agua Pag 67

Water hemisphere/ Semiesfera de agua Pag 68

Nozzles/  
Boquillas



This type of fountain nozzle requires a separate mention, given its special appearance and performance. It could be catalogued as crystalline because each individual jet pipe generates a disc of transparent water, but **the end result is the combination of hundreds of discs that create a remarkable spherical (or semi-spherical) volume.** Furthermore, because it moves a large volume of water, it forms an extremely large column when it falls.

Catalogación aparte merece este tipo de boquillas para fuentes, por su particular aspecto y comportamiento. Se podrían catalogar como cristalinas porque cada tobera individual genera un disco de agua transparente, pero **el resultado final es la unión de cientos de discos que genera un volumen esférico (o semiesférico)** que es el que cabe destacar, además, al mover grandes volúmenes de agua, en su caída forman un cilindro de gran dimensión.



# Water sphere/ Esfera de agua

The aim is to generate a spherical pattern and a high volume column of water when the water falls. Each fountain nozzle produces an outlet disc that joins the ones around it to create fascinating patterns. An entire series of sizes is available, which makes it suitable for use in both small indoor fountains and large outdoor water features.

El objetivo es generar una forma esférica de agua y un cilindro de gran volumen cuando ese agua cae. Cada boquilla genera en su salida un disco que se junta con los que tiene a su alrededor creando formas geométricas curiosas de observar. Existe una serie completa en función de los tamaños, lo que hace que se adapte tanto a pequeñas fuentes de interior como a grandes fuentes de exterior.

Brass + Stainless steel/ Latón + Acero Inox.



Nozzles/  
Boquillas

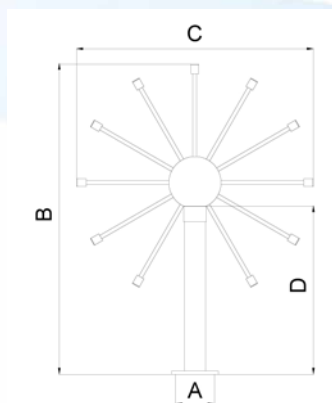

Water appearance/ Aspecto del agua Clear/ Cristalino  
 Wind resistance/ Resistencia al viento ★★★★★  
 Splash/ Salpicadura ★★★★★  
 Sound level/ Nivel de sonido ★★★★★  
 Visibility/ Visibilidad ★★★★★

Minisphere/ Miniesfera  
 Mini hemispheres/  
 Minisemieferras

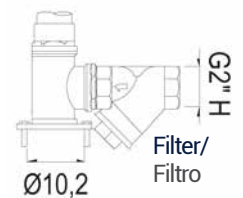

	MINI-WATER SPHERES/ MINIESFERAS DE AGUA			WATER SPHERES/ ESFERAS DE AGUA				
Reference/ Referencia	F2552016	F2552027	F2552038	F2563018	F2563029	F2564019	F2564021	F2564032
Connection/ Conexión A	G 2" F/H BSP	G 2" F/H BSP	G 2" F/H BSP	DN 80	DN 80	DN 100	DN 100	DN 100
Length/ Long. (cm) B x C	120 x Ø60	150 x Ø75	180 x Ø90	180 x Ø90	240 x Ø120	300 x Ø150	480 x Ø240	600 x Ø300
Length/ Long. (cm) D	83	105	128	127	172	214	349	439
Spokes number/ N° de Radios	39 x Ø10 mm	85 x Ø10 mm	115 x Ø10 mm	36 x Ø16 mm	76 x Ø16 mm	146 x Ø16 mm	221 x Ø16 mm	246 x Ø16 mm
Flow/ Caudal (L/min)	117	255	345	360	760	1460	2210	2952
Pressure/ Presión	3,60	4,00	4,50	3,90	4,80	5,70	7,40	9,20
Material/ Material	Brass/ Latón	Brass/ Latón	Brass/ Latón	Brass + Stainless steel	Brass + Stainless steel	Brass + Stainless steel	Brass + Stainless steel	Brass + Stainless steel
Weight/ Peso (kg)	18 kg	19 kg	20 kg	20 kg	43 kg	76 kg	129 kg	174 kg

Further information at [www.saferain.com](http://www.saferain.com) | Más información en [www.saferain.com](http://www.saferain.com)



# Water hemispheres/ Semiesferas de agua

The main difference between water hemisphere and water spheres is that the water outlet pattern only covers the top half of the sphere. This enhances the cone of falling water, as the lower hemisphere does not interfere with its operation. The basic operating system is the same as for full spheres and it also comes in a **wide range of sizes for use in small or large indoor fountains and outdoor water features.**

La principal diferencia con las esferas de agua es que las salidas de agua sólo ocupan la mitad superior de la esfera. Este hecho acentúa el cono de caída del agua ya que no interfiere la semiesfera inferior en su funcionamiento. El funcionamiento básico es el mismo que en las esferas de agua y también existe un **abanico grande de tamaños para su utilización en pequeñas fuentes de interior o grandes fuentes de exterior.**



**Brass + Stainless steel/ Latón + Acero Inox.**

**AISI 304**

**ON STOCK**

Water appearance/ Aspecto del agua Clear/ Cristalino  
 Wind resistance/ Resistencia al viento ★★☆☆☆☆  
 Splash/ Salpicadura ★★★★★☆  
 Sound level/ Nivel de sonido ★★★★★☆  
 Visibility/ Visibilidad ★★★★★☆

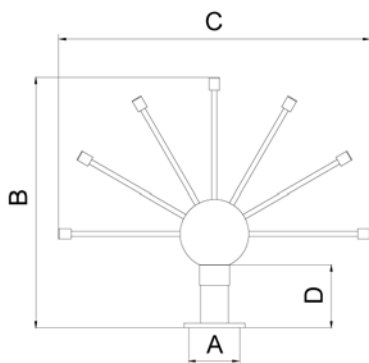

	MINI-WATER HEMISPHERES/ MINISEMIESFERAS DE AGUA			WATER HEMISPHERES/ SEMIESFERAS DE AGUA				
Reference/ Referencia	F2572018	F2572029	F2572031	F2583011	F2583022	F2584012	F2584023	F2584034
Connection/ Conexión A	G 2" F/H BSP	G 2" F/H BSP	G 2" F/H BSP	DN 80	DN 80	DN 100	DN 100	DN 100
Length/ Long. (cm) B x C	60 x Ø60	75 x Ø75	90 x Ø90	90 x Ø90	120 x Ø120	150 x Ø150	240 x Ø240	300 x Ø300
Length/ Long. (cm) D	23	30	38	37	52	64	109	139
Spokes number/ N° de Radios	24 x Ø10 mm	52 x Ø10 mm	64 x Ø10 mm	26 x Ø16 mm	46 x Ø16 mm	91 x Ø16 mm	126 x Ø16 mm	136 x Ø16 mm
Flow/ Caudal (L/min)	72	156	192	312	552	1092	1512	1632
Pressure/ Presión	3,00	3,25	3,60	3,00	3,60	4,20	6,20	6,20
Material/ Material	Brass/ Latón	Brass/ Latón	Brass/ Latón	Brass + Stainless steel	Brass + Stainless steel	Brass + Stainless steel	Brass + Stainless steel	Brass + Stainless steel
Weight/ Peso (kg)	14 kg	16 kg	18 kg	15 kg	22 kg	41 kg	77 kg	98 kg

Further information at [www.saferain.com](http://www.saferain.com) | Más información en [www.saferain.com](http://www.saferain.com)

# Bespoke nozzles/ Boquillas a medida

## DISTRIBUTION BOXES/ CAJAS DE REPARTO

### 1- CHOOSE A SIZE

Choose in between our distribution boxes sizes.

### 2- MAKE A DESIGN

Choose nozzles and their position from our catalogue. (Technical advice will be given for proper performance)

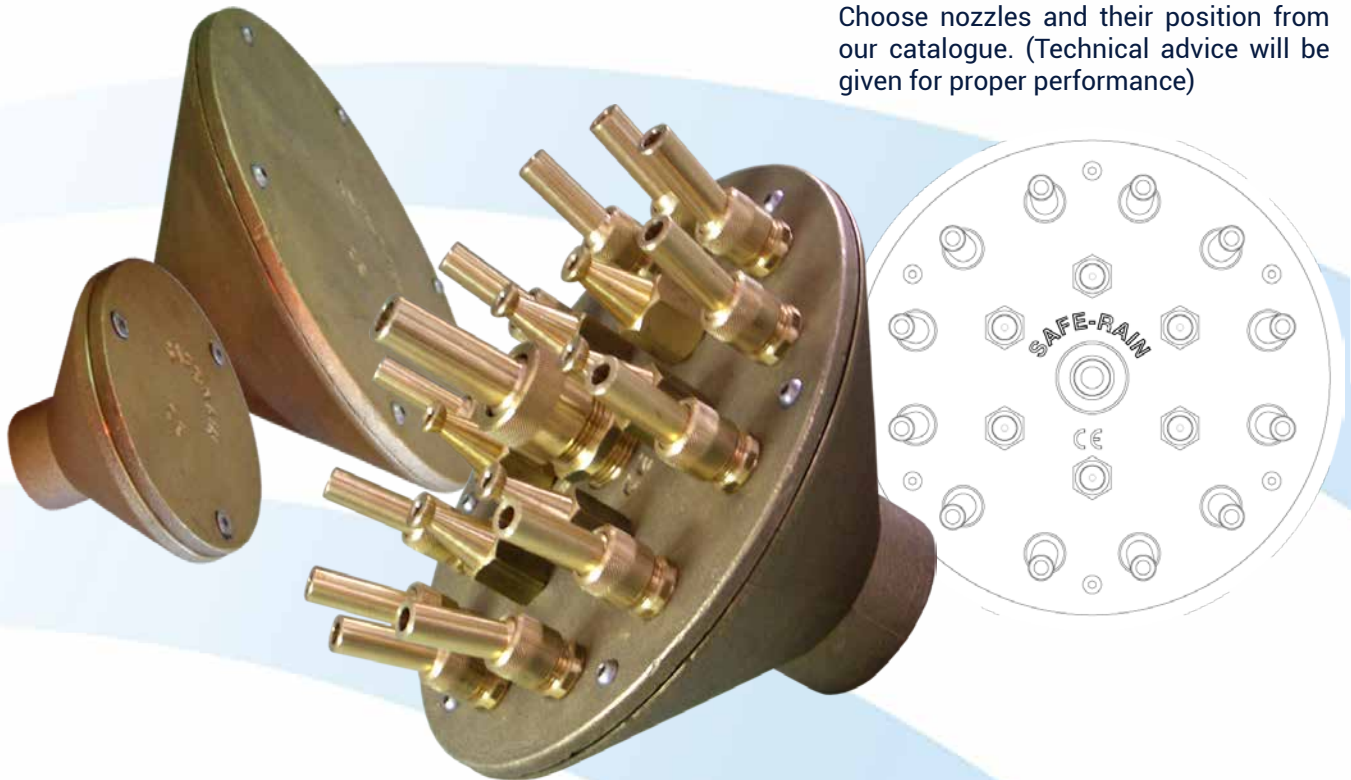

### 3- MANUFACTURE

Product will be delivered reviewed and tested.

Our distribution boxes are specifically designed to obtain **bespoke water features that suits your needs**, due to the top cover, you can put different nozzles which offers the possibility of getting multiple water effects in a the architectural fountain. This product leaves the door open to your imagination to get in a single component the desired water jets.

Beginning with distribution boxes we obtained different products like spraying clouds, palm tree nozzle or special crowns, all of them are a clear example of the wide variety of water effects you can get.

Nuestras cajas de reparto están expresamente diseñadas para **conseguir los juegos de agua que se adapten a tus necesidades** ya que en su tapa superior puedes colocar diferentes boquillas gracias a las cuales conseguirás múltiples efectos acuáticos en una fuente. Este producto deja la puerta abierta a tu imaginación para que con un solo componente consigas el juego de chorros deseado.

Partiendo de las cajas de reparto hemos obtenido diferentes productos como las nubes de pulverización, la palmera o las coronas especiales, todos ellos suponen un claro ejemplo de la gran diversidad de juegos acuáticos que puedes obtener.



# FOUNTAIN LIGHTING/ ILUMINACIÓN DE FUENTES

Ocean LED light/ Foco Ocean Pag 71

Sea LED ring/ Corona LED Sea Pag 72

Lake LED light/ Foco LED Lake Pag 74

PAR38 light/ Foco PAR38 Pag 76

Dichroic lightfixtures/ Foco halógeno dicroico Pag 77

PAR56 light/ Foco PAR56 Pag 78

3 Dichroic ring/ Corona de 3 dicroicos Pag 79



Lighting/  
Iluminación

**W**hen it comes to fountain lighting, a distinction can be made between lights using **LED (Light Emitting Diode) technology and incandescent lights**. In absolute terms, it is still not possible to achieve the same lighting values with LED lights as it is with incandescent lights. However in relative terms (lumens emitted per consumed watt), it is worth highlighting that the predominant trend is clearly in favor of LED lights. Applying everything outlined above to the fountain lighting, **we generally recommend the use LED fountain lights to light up water jets with a height of up to 10m or large volumes of water, compared to incandescent lights that reach an optimal performance with water jets of a greater height.**

**T**anto en la iluminación de fuentes como en la iluminación convencional podemos diferenciar las lámparas con **tecnología LED (Light Emitting Diode) y las lámparas de incandescencia**, que a su vez pueden ser halógenas o no. Con las lámparas de LED aún no se puede alcanzar, en términos absolutos, los mismos valores de iluminación que con las lámparas de incandescencia. En cambio, en términos relativos (los lúmenes emitidos por vatio consumido) cabe destacar que el predominio es claramente favorable a las lámparas de LED. Aplicando todo lo anteriormente dicho a la iluminación de fuentes **recomendamos el uso de focos de led sumergibles para iluminar chorros de agua de hasta 10 m de altura o grandes volúmenes de agua, frente a los focos de incandescencia cuyo rendimiento es óptimo en chorros de agua de mayor altura.**



# Ocean LED light/ Foco Ocean

The **Ocean submersible LED light** is the result of our constant search of the excellence. Lighting available in 36W and 120 W LED High performance, optional RGB, RGBW, and WHITE, also 10° or 30° lenses, IP 68 connector included, DMX controllable. Manufactured in brass and Stainless Steel AISI-304, **new slim design, is strong and very light, IP68 certified.** High heat dissipation, thanks to the large contact area.

El **foco LED sumergible Ocean** es el resultado de nuestra continua búsqueda de la excelencia. Iluminación disponible en 36W y 120W de potencia LED de alto rendimiento y opcional RGB, RGBW, BLANCO, y ópticas 10° o 30°, conector incluido, controlables DMX. Fabricado en Latón y Acero Inoxidable AISI-304, **diseño extra-plano, es un foco robusto, muy ligero y certificado IP 68.** Alta disipación de calor, gracias a la gran superficie de contacto.



Certifications/ Certificaciones

**IP68 CE**

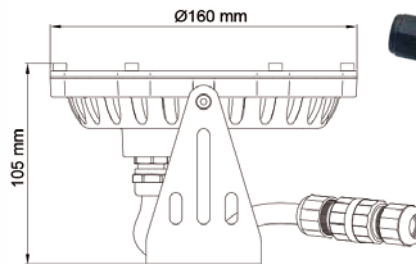

Light charts/ Gráficos de iluminación.

Spot/ Intensivo (Beam 10°)							Flood/ Extensivo (Beam 30°)						
Color	White/ Blanco		RGB		RGB W		Color	White	RGB		RGBW		
Distance/ Distancia	Beam/ Haz de luz (m)	Centre/ Centro	Beam/ Haz de luz (m)	Centre/ Centro	Beam/ Haz de luz (m)	Centre/ Centro	Distance/ Distancia	Beam/ Haz de luz (m)	Centre/ Centro	Beam/ Haz de luz (m)	Centre/ Centro	Beam/ Haz de luz (m)	Centre/ Centro
1 m	Ø 0,24	16808 lx	Ø 0,21	12063 lx	Ø 0,21	18300 lx	1 m	Ø 0,34	10171 lx	Ø 0,30	6095 lx	Ø 0,30	15284 lx
2 m	Ø 0,48	4202 lx	Ø 0,42	3016 lx	Ø 0,42	4560 lx	2 m	Ø 0,68	2543 lx	Ø 0,59	1524 lx	Ø 0,59	3336 lx
3 m	Ø 0,73	1867 lx	Ø 0,63	1340 lx	Ø 0,63	2030 lx	3 m	Ø 1,03	1130 lx	Ø 0,89	677 lx	Ø 0,89	1614 lx
4 m	Ø 0,97	1050 lx	Ø 0,84	754 lx	Ø 0,84	1150 lx	4 m	Ø 1,37	636 lx	Ø 1,19	381 lx	Ø 1,19	882 lx
5 m	Ø 1,21	672 lx	Ø 1,05	482 lx	Ø 1,05	732 lx	5 m	Ø 1,71	407 lx	Ø 1,49	244 lx	Ø 1,49	520 lx
7 m					Ø 1,47	370 lx						Ø 2,09	288 lx
9 m					Ø 1,89	220 lx						Ø 2,68	190 lx

Electrical data/ Datos eléctricos								Details/ Detalles			
Reference/ Referencia	Power/ Potencia	Voltage/ Voltaje	Beam angle/ Ángulo	Color/ Color	LEDs Num./ Nº de LEDs	Lumens/ Lúmens	Life span/ Vida útil	Material/ Material	Weight/ Peso	Elect. connection/ Conexión eléctrica	
F5210201	36 W	24V DC	10°	White 6500K	12	1486 lm	40000/hrs	STAINLESS STEEL AISI-304 - BRASS/ ACERO INOXIDABLE AISI-304 - LATÓN	1,63 kg	0,5 m cable with IP68 connector H05RR-F/H05RN-F H07RR-F/H07RN-F Ø 5 - Ø 12	
F5210212			30°			1524 lm					
F5215206			10°	702,9 lm							
F5215217			30°	702,3 lm							
F5216409	120 W		10°	RGBW		5000 lm				0,5 m cable with IP68 connector H05RR-F/H05RN-F H07RR-F/H07RN-F Ø 10 - Ø 13	
F5216411			30°								

Further information at [www.saferain.com](http://www.saferain.com) | Más información en [www.saferain.com](http://www.saferain.com)

# Led ring SEA Series/ Corona de LED Gama SEA

New generation of the LED corona SEA, made of brass and AISI – 304 stainless steel, offers a 1 "H threaded connection for a nozzle to be mounted directly, and one of 1 ½"H for the water inlet, designed for the light beam to shine from behind the water jet accurately and effectively. We have increased the options by incorporating new and more efficient LED circuits that deliver 566 Lumens -, SEA 250 RGB; , 896 Lm, - SEA 500 RGB; 1,200 Lm, - SEA 500 White. In addition, thanks to the lens angle of 10° or 30°, we managed to optimize the range and intensity of the light source. Its optimized and elegant finish is complimented with high performance, enjoying a useful life far superior to any other component of the ornamental fountain.

Nueva generación de la corona de LED SEA, fabricada en latón y acero inoxidable AISI – 304, ofrece una conexión roscada de 1 "H para que una boquilla se monte directamente, y 1 ½"H para la entrada de agua, diseñadas para que el haz de luz siga el chorro de agua de forma precisa y eficaz, hemos incrementado las opciones incorporando nuevos y más eficientes circuitos de LED que entregan 566 Lúmenes - SEA 250 RGB , 896 Lm - SEA 500 RGB y 1.200Lm - SEA 500 Blanco. Además, gracias al ángulo de lente de 10° o 30°, conseguimos optimizar el alcance y la intensidad del flujo luminoso. También son controlables DMX, añadiendo los elementos necesarios para ello. Su acabado, optimizado y elegante se completa con unas elevadas prestaciones, gozando de una vida útil muy superior a cualquier otro componente de la fuente ornamental.

AISI 304

IN STOCK

LED

RGB

RGBW

PWM

DMX



## PRODUCT FEATURES/ CARACTERÍSTICAS DEL PRODUCTO

- Brass body with top cover in stainless steel AISI 304.
- Light fixture designed for optimum heat transferal, which considerably extends the useful life of the LEDs as well as maintaining their high performance.
- IP 68 certificate granted by accredited external laboratory.
- Different input voltages of 12V and 24V.
- 100% safe connections.
- 9 high performance LEDs.
- Controllable by PWM and DMX.
- RGB, RGBW and white lighting.
- LEDs self-protected by reverse polarity.
- 1 "M BSP/NPT top thread for nozzles.
- Lower 1-1/2 "H BSP/NPT thread as for water inlet.
- Cuerpo de latón con cubierta superior en acero inoxidable AISI 304.
- Luminaria diseñada para la perfecta evacuación del calor lo que alarga considerablemente la vida útil de los LED así como mantener su alto rendimiento lumínico.
- Homologación IP 68 por laboratorio externo autorizado.
- Distintas tensiones de entrada de 12 y 24Vdc.
- Conexiones seguras 100%.
- 9 LED's de alto rendimiento.
- Controlable por PWM y DMX.
- Iluminación RGB, RGBW y blanca.
- LED's auto protegidos de polaridad inversa.
- Rosca superior de 1"M BSP/NPT para toberas.
- Rosca inferior de 1- 1/2"H BSP/NPT para la entrada de agua.

# SEA LED Fountain Ring/ Corona de LED SEA

## Electrical data/ Datos eléctricos

Reference/ Referencia	Model/ Modelo	Col- our/ Color	Beam angle/ Ángulo	Maximum luminous flux/ Máximo flujo luminoso	Power con- sumption/ Consumo de potencia	Voltage/ Voltaje	Electrical connection/ Conexión eléctrica	Weight/ Peso	
F5715145	250	RGB	10°	566 lm	17W	12/24V DC	Plug & Socket/ Conector enchufable IP68 Connector H05RRR-F/H05RN-F H07RR-F/H07RN-F 07 - 012	1,2 kg	
F5715156			30°						
F5710149	500	White/ Blanco 6500K	10°	1200 lm	21W				
F5710151			30°						
F5715549		RGB	10°		896 lm				22W
F5715551			30°						

## Dimensions/ Dimensiones

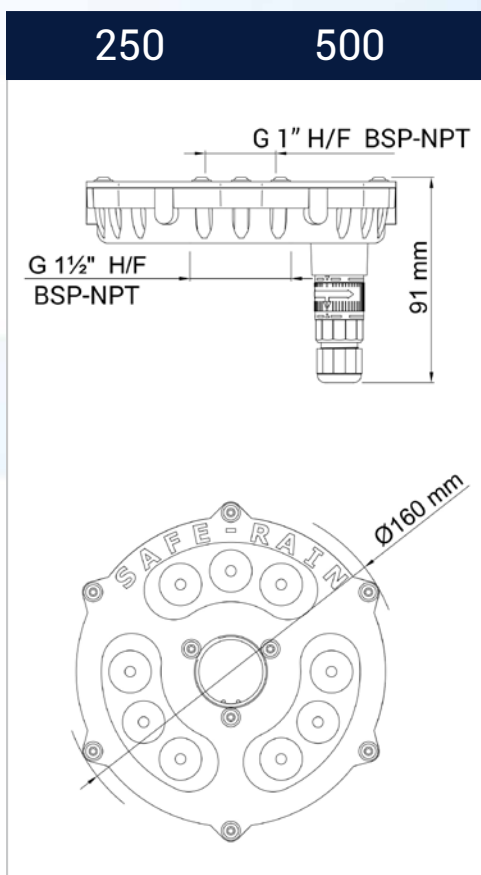

## Light charts/ Datos de iluminación

10°		250	500	
		RGB	White/ Blanco	RGB
Distance/ Distancia	Beam diameter/ Diámetro de Haz de luz (m)	Center/ Centro	Center/ Centro	Center/ Centro
1 m		Ø 0,17	10769 lx	12948 lx
2 m		Ø 0,35	2692 lx	3237 lx
3 m		Ø 0,52	1197 lx	1439 lx
4 m		Ø 0,70	673 lx	809 lx
5 m		Ø 0,87	431 lx	528 lx
6 m		Ø 1,05		562 lx
7 m		Ø 1,22		413 lx

30°		250	500	
		RGB	White/ Blanco	RGB
Distance/ Distancia	Beam diameter/ Diámetro de Haz de luz (m)	Center/ Centro	Center/ Centro	Center/ Centro
1 m		Ø 0,53	4832 lx	8051 lx
2 m		Ø 1,07	1208 lx	2013 lx
3 m		Ø 1,61	537 lx	895 lx
4 m		Ø 2,14	302 lx	503 lx
5 m		Ø 2,68		322 lx
6 m				
7 m				



IP68 CE



# Lake LED light/ Foco LED Lake

Our Lake light with **submersible LED technology**, crafted from **IP68 stainless steel** and **designed expressly for fountain lighting**, ponds and gardens, houses a high-performance AR-111 LED bulb. It is manufactured from 1.5 mm sheeting using a stainless steel stamping process, making it both **extremely light and resistant to corrosion and aging processes**.

Nuestro foco Lake con **tecnología LED sumergible de acero inoxidable IP68**, está expresamente diseñado para **iluminación de fuentes ornamentales, estanques y jardines**, alberga una lámpara LED de alto rendimiento tipo AR-111. Está fabricado mediante el proceso de estampación de acero inoxidable con chapa de 1,5mm lo cual hace que sea **muy ligero y resistente a procesos de corrosión**.



Certifications/ Certificaciones

IP68 CE

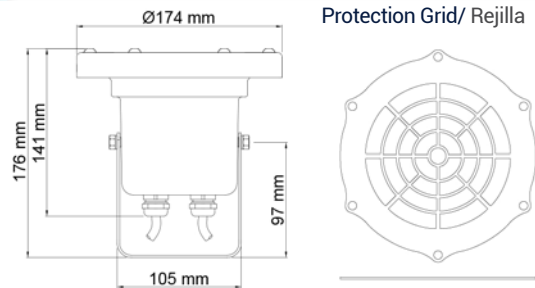

Light charts/ Gráficos de iluminación.

Spot/ Intensivo (Beam 10°)				
Power		11 W		13,2W
Color	Beam / Haz de luz (m)	White 6000K	RGB	White 3000K
Dist.		Centre/ Centro	Centre/ Centro	Centre/ Centro
1 m	Ø 0,22	8100 lx	5246 lx	8800 lx
2 m	Ø 0,45	2025 lx	1311 lx	2220 lx
3 m	Ø 0,68	900 lx	582 lx	978 lx
4 m	Ø 0,91	506 lx	328 lx	550 lx
5 m	Ø 1,13	324 lx	210 lx	352 lx

Flood/ Extensivo (Beam 30°)				
Power		11 W		13,2W
Color	Beam / Haz de luz (m)	White 6000K	RGB	White 3000K
Dist.		Centre/ Centro	Centre/ Centro	Centre/ Centro
1 m	Ø 0,34	6376 lx	3500 lx	7540 lx
2 m	Ø 0,69	1594 lx	875 lx	1885 lx
3 m	Ø 1,04	708 lx	389 lx	838 lx
4 m	Ø 1,38	398 lx	219 lx	471 lx
5 m	Ø 1,73	255 lx	140 lx	302 lx

Electrical data/ Datos eléctricos

Reference/ Referencia	Power/ Potencia	Voltage/ Voltaje	Beam angle/ Ángulo	Color/ Color	LEDs Num./ N° de LEDs	Lumens/ Lúmens	Life span/ Vida útil	Lamp/ Lámpara	Material/ Material	Weight/ Peso	Elect. connection/ Conexión eléctrica	
F5207038	13,2 W	12/24V DC	10°	White 3000K	12	1150 Lm	40000 hrs	F5643088	Stainless steel AISI-304/ Acero Inoxidable AISI-304	1,7 kg	G 53 Lamp 2PG 16 Ø6/9/12	
F5207027			30°	White 3000K				F5643066				
F5200031	10°		White 6000K	772,5 lm	F5643044	R,G,B COM Lamp 2PG 16 Ø6/9/12						
F5200029	30°		White 6000K		F5643011							
F5205036	10°		RGB	443 lm	F5643549							
F5205025	30°		RGB	443 lm	F5643516							
F5201008	10°		R	110 lm	F5643145							
F5203001	10°		G	260 lm	F5643347							
F5204002	10°		B	65 lm	F5643448	G 53 Lamp 2PG 16 Ø6/9/12						
F5201019	30°		R	125 lm	F5643112							
F5203012	30°		G	275 lm	F5643314							
F5204013	30°		B	75 lm	F5643415							
F5208502	9 W	12V AC	10°	RGB (AUTO)	6		443 lm	F5643843				
F5208513			30°	RGB (AUTO)				F5643819				
F5200007			Whithout lamp/ Sin lámpara									
										1,4 kg	2PG 16 Ø6/9/12	

# Lake LED light / Foco LED Lake

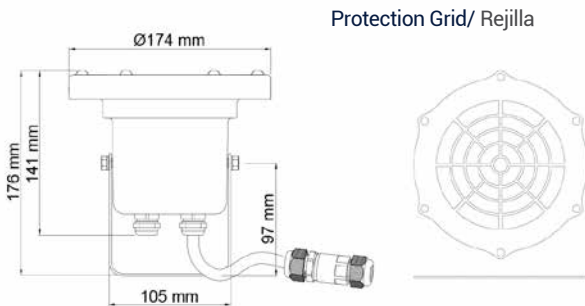

Certifications/ Certificaciones **IP68 CE**



Lighting/  
Iluminación

## Light charts/ Gráficos de iluminación.

Spot/ Intensivo (Beam 10°)				Spot/ Intensivo (Beam 30°)			
Power	27 W			Power	27 W		
Color	RGB			Color	White	RGB	
Dist.	Beam / Haz de luz (m)	Centre/ Centro		Dist.	Beam / Haz de luz (m)	Centre/ Centro	Centre/ Centro
1 m	Ø 0,21	10236 lx		1 m	Ø 0,32	8250 lx	4866 lx
2 m	Ø 0,42	2559 lx		2 m	Ø 0,63	2062 lx	1216 lx
3 m	Ø 0,63	1137 lx		3 m	Ø 0,95	918 lx	504 lx
4 m	Ø 0,84	640 lx		4 m	Ø 1,26	515 lx	304 lx
5 m	Ø 1,05	409 lx		5 m	Ø 1,58	330 lx	194 lx

Electrical data/ Datos eléctricos							Details/ Detalles			
Reference/ Referencia	Power/ Potencia	Voltage/ Voltaje	Beam angle/ Ángulo	Color/ Color	LEDs Num./ Nº de LEDs	Lumens/ Lúmens	Life span/ Vida útil	Material/ Material	Weight/ Peso	Elect. connection/ Conexión eléctrica
F5200119	27 W	24V DC	30°	White 6500K	9	1256 lm	40000/hrs	STAINLESS STEEL AISI-304/ ACERO INOXIDABLE AISI-304	1,7 kg	0,5 with connector IP68/ with connector IP68 H <sub>05</sub> R <sub>N</sub> - F07 - Ø12 mm
F5205137		12/24V DC	10°	RGB		593 lm				
F5205115			30°							

Further information at [www.saferain.com](http://www.saferain.com) | Más información en [www.saferain.com](http://www.saferain.com)

# PAR 38 Lightfixture/ Foco PAR 38

Both models are fitted with windows to ensure that the light is kept cool at all times, thereby considerably lengthening its useful life. **Should be installed underwater.** IP 68 certification, rubber joint with triple protection. They can be sold with 12, 24 and 230 V/AC bulbs, making them **adaptable to any standard.** Their power ranges from 80 to 120W. As options, there is also a range of color filters and light protection grates.

Ambos modelos tienen unas ventanas que hace que la lámpara esté refrigerada en todo momento, lo que alarga considerablemente la vida útil de la misma. **Deben instalarse sumergidos.** Certificación IP 68, junta de caucho con triple protección. Se pueden comercializar con lámparas de 12, 24 y 230 V/AC lo que **permite adaptarse a cualquier normativa.** Opcionalmente también existen filtros de color y rejillas protectoras de la lámpara.



Polypropylene

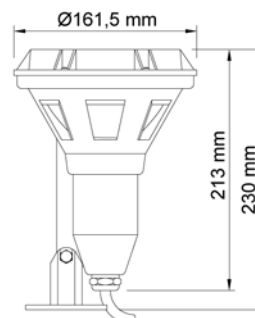

Brass

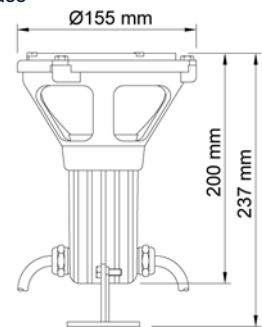

Certifications/ Certificaciones

IP68 CE



Light charts/  
Gráficos de iluminación.

Spot/ Intensivo (Beam 10°)		
Power	100 W + 120 W	
Distance/ Distancia	Beam/ Haz de luz (m)	Centre/ Centro
2 m	Ø 0,40	2375 lx
4 m	Ø 0,84	595 lx
6 m	Ø 1,26	265 lx

Flood/ Extensivo (Beam 30°)				
Power	80 W (*)		100 W + 120 W	
Distance/ Distancia	Beam/ Haz de luz (m)	Centre/ Centro	Beam/ Haz de luz (m)	Centre/ Centro
1 m	Ø 0,53	1800 lx	Ø 0,53	3100 lx
2 m	Ø 1,07	450 lx	-	-
3 m	-	-	Ø 1,60	344 lx
4 m	Ø 2,14	112 lx	-	-
5 m	-	-	Ø 2,60	124 lx

Details/ Detalles				Electrical data/ Datos eléctricos				
Polypropylene + Fiberglass/ Polipropileno + Fibra de vidrio		Brass/ Latón		Lamp/ Lámpara				
Reference/ Referencia	Weight/ Peso	Reference/ Referencia	Weight/ Peso	Voltage/ Voltaje	Power/ Potencia	Light beam/ Haz de luz		Lamp/ Lámpara
Reference/ Referencia	Weight/ Peso	Reference/ Referencia	Weight/ Peso			Spot/ Intensivo	Flood/ Extensivo	
F5312801 (*)	1,0 Kg	F5322813 (*)	2,7 Kg	220 V AC	80 W		✓	F5632817
F5312103	1,0 Kg	F5322115	2,7 Kg	220 V AC	120 W		✓	F5632119
F5314105	1,0 Kg	F5324117	2,7 Kg	24 V AC	120 W	✓		F5634112
F5311405	1,0 Kg	F5321406	2,7 Kg	12 V AC	100 W		✓	F5631423
F5331719	1,0 Kg	F5321711	2,7 Kg	12 V AC	75 W	✓		F5631726
F5330913	1,0 Kg	F5340914	2,7 Kg	12 V AC	10 W	White LEDs/ LEDs Blanco		F5641514
F5338911	1,0 Kg	F5348913	2,7 Kg	12 V AC	10 W	RGB		F5641018
F5310009	-	F5320012	-	Without lamp/ Sin lámpara				

Further information at [www.saferain.com](http://www.saferain.com) | Más información en [www.saferain.com](http://www.saferain.com)



# Dichroic lightfixtures/ Foco dicroico

**P**lastic and stamped brass models are offered. They house lights with a power up to 50 W. The cable glands fitted to them are designed and manufactured by Safe-Rain, with the complete safety of the **IP68 protection rating**. This data shows that **these lights are very suitable for lighting secondary effects in architectural water features**.

**E**xiste el modelo de plástico y de latón estampado. Alberga en su interior una lámpara de hasta 50W de potencia. Los prensaestopas que llevan son diseñados y fabricados por Safe-Rain, con la total seguridad de conseguir un grado de **protección IP68**. **Estos datos hacen que estos focos sean muy adecuados para iluminar efectos secundarios en fuentes ornamentales.**

Certifications/ Certificaciones **IP68 CE**

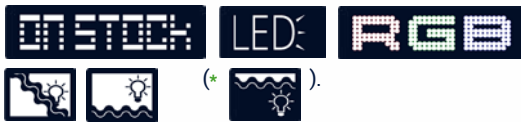

Light charts/ Gráficos de iluminación.

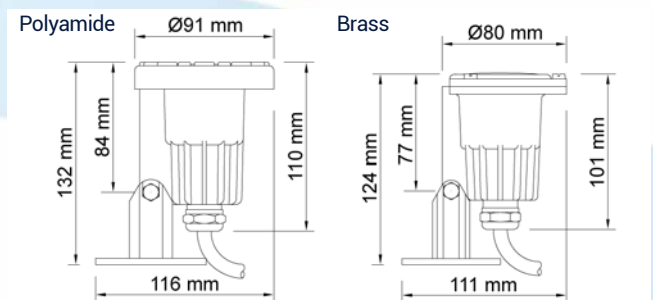

Spot/ Intensivo				
Power	20 W		50 W (*)	
Distance/ Distancia	Beam/ Haz de luz (m)	Centre/ Centro	Beam/ Haz de luz (m)	Centre/ Centro
2 m	Ø 0,35	1000 lx	Ø 0,35	2500 lx
4 m	Ø 0,70	250 lx	Ø 0,70	625 lx
6 m	Ø 1,40	111 lx	Ø 1,40	277 lx

Flood/ Extensivo				
Power	20 W		50 W (*)	
Distance/ Distancia	Beam/ Haz de luz (m)	Centre/ Centro	Beam/ Haz de luz (m)	Centre/ Centro
1 m	Ø 0,60	700 lx	Ø 0,60	2000 lx
2 m	Ø 1,30	175 lx	Ø 1,30	500 lx
3 m	Ø 2,00	78 lx	Ø 2,00	222 lx

Details/ Detalles				Electrical data/ Datos eléctricos										
Polyamide 6-6/ Po- liamida 6-6		Brass/ Latón		Transformer/ Transformador	Lamp/ Lámpara					Life span/ Vida útil	Lamp Ref./ Ref. Lámpara	Elect. Conec./ Conex. Elect.		
Reference/ Referencia	Weight/ Peso	Reference/ Referencia	Weight/ Peso		Voltage/ Volaje	Power/ Potencia	Type/ Tipo	Beam angle/ Ángulo	Color/ Color				LEDs num./ N° de LEDs	Intensity/ Intensidad
F5431217	0,35 Kg	F5441218	0,94 Kg		12 V AC	20 W	Halogen/ Halógenas	10°	3000 K	-	6000 cd	4000 Hrs	F5631219	
F5431228	0,35 Kg	F5441229	0,94 Kg		12 V AC	20 W		36°		-	1000 cd		F5631221	
F5431511 (◌)	0,35 Kg	F5441512 (◌)	0,94 Kg		12 V AC	50 W		10°		-	15000 cd		F5631513	
F5431522 (◌)	0,35 Kg	F5441523 (◌)	0,94 Kg		12 V AC	50 W		36°		-	2850 cd		F5631524	
F5431239	1,69 Kg	F5441231	2,28 Kg	✓	12 V AC	20 W		36°		-	1000 cd		F5631211	
F5431533 (◌)	1,69 Kg	F5441534 (◌)	2,28 Kg	✓	12 V AC	50 W		36°		-	2850 cd		F5631524	
F5455901	0,36 Kg	F5465902	0,96 Kg		12 V AC	2 W	LED	60°	RGB (Auto)	21	65 lm	30000/ 40000 Hrs	F5642526	
F5450411	0,36 Kg	F5460412	0,96 Kg		12 V AC	6 W		38°	White 6500 K	1	480 lm		F5642098	
F5457418	0,36 Kg	F5467419	0,96 Kg		12 V AC	6 W		38°	Warm White 3000 K	1	480 lm		F5642043	
F5455326	0,36 Kg	F5465327	0,96 Kg		12 V AC	5 W		60°	RGB (Auto)	1	130 lm		F5642561	
F5451017	0,36 Kg	F5461018	0,96 Kg		12 V AC	5 W		30°	R	4	140 lm		F5642111	
F5453019	0,36 Kg	F5463011	0,96 Kg		12 V AC	5 W		30°	G	4	240 lm		F5642313	
F5454011	0,36 Kg	F5464012	0,96 Kg		12 V AC	5 W		30°	B	4	80 lm	F5642414		
F5430014	0,32 Kg	F5440015	0,91 Kg		Without lamp/ Sin lámpara									

Lightfixtures with voltage transformer includes 5m cable/ Los focos con transformador incluyen cable 5m

Lighting/  
Iluminación

# PAR 56 Lightfixture/ Foco PAR 56

**P**AR-56 light is specifically developed for heavy use for the lighting of swimming pools. Available in many different types, all sold by SAFE RAIN: PAR 56, over traditional size in white and with automatic RGB changes, reducing installation costs as a separate RGB controller is not necessary; this light also exists in an extra flat model.

**E**ste tipo de lámparas están desarrolladas por utilizarse para la iluminación de piscinas. Existen muchas variedades de esta lámpara, todas comercializadas por SAFE RAIN: la PAR 56 de tamaño tradicional en blanco y con cambios automáticos RGB, lo que hace que no sea necesario un controlador RGB, reduciendo el coste de la instalación; existe otro modelo de lámpara de este tipo que es extraplana.



Certifications/ Certificaciones

IP68 CE



Measures (mm)		A	B	C	D	E
Polypropylene		211,5	172	Ø 231	155	-
Brass		211,5	175,5	Ø 199	155	218
Slim/ Plana	Polypropylene (*)	179,5	66	Ø 231	123,5	-
	Brass (*)	172,5	62	Ø 199	123,5	218

Polypropylene

Brass

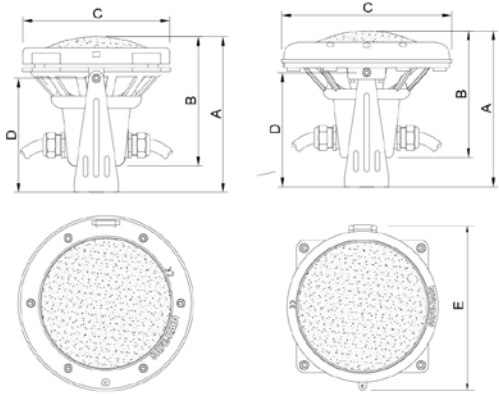

Light charts/ Gráficos de iluminación.

Spot/ Intensivo			Spot/ Intensivo LED			Flood/ Extensivo				
Power	230V AC/ 300 W		Power	12V AC/ 35W		Power	12V AC/ 300 W		230V AC/ 300 W	
Distance/ Distancia	Beam/ Haz de luz (m)	Centre/ Centro	Distance/ Distancia	Beam/ Haz de luz (m)	Centre/ Centro	Distance/ Distancia	Beam/ Haz de luz (m)	Centre/ Centro	Beam/ Haz de luz (m)	Centre/ Centro
2 m	Ø 0,8	5500 lx	0,5 m	Ø 0,5	3800 lx	2 m	Ø 3,3	2625 lx	Ø 3,3	2250 lx
4 m	Ø 1,7	1375 lx	1 m	Ø 1,6	1380 lx	4 m	Ø 6,7	656 lx	Ø 6,7	560 lx
8 m	Ø 3,4	343 lx	1,5 m	Ø 2,5	694 lx	6 m	Ø 10,0	291 lx	Ø 10,0	250 lx
			2 m	Ø 3,3	400 lx					

Details/ Detalles

Electrical data/ Datos eléctricos

Polypropylene + Fiber-glass/ Polipropileno + Fibra de vidrio				Brass/ Latón		Lamp/ Lámpara							Elect. Connection/ Conex. Elect.
Reference/ Referencia	Weight/ Peso	Reference/ Referencia	Weight/ Peso	Voltage/ Voltaje	Power/ Potencia	Type/ Tipo	Beam angle/ Angulo	Color/ Color	Intensity/ Intensidad	Life span/ Vida útil	Lamp/ Lámpara		
F5351308	2,4 Kg	F5361309	6,0 Kg	12 V AC	300 W	Incandescence/ Incandescencia	30°	2750 K	6000 lm	1000 Hrs	F5631311	2PG 21 Ø11,7/15/18,6	
F5352309	2,4 Kg	F5362301	6,0 Kg	230 V AC	300 W		30°		3450 lm		2000 Hrs		F5632323
F5352311	1,9 Kg	F5362312	6,0 Kg	230 V AC	300 W		19°		3450 lm	F5632312			
F5510013	2,4 Kg	F5520014	6,0 Kg	12 V AC	45 W	LED	-	White 6500 K	1050 lm	25000 Hrs	F5644091		2PG 16 Ø7/9/12
F5515018	2,4 Kg	F5525019	6,0 Kg	12 V AC	35 W		-	RGB (Auto)	390 lm		F5644517		
F5530915 (*)	2,1 Kg	F5540916 (*)	3,0 Kg	12 V AC	35 W	LED Slim (4m cable)	160°	White 6500 K	1766 lm		F5645092		
F5535911 (*)	1,6 Kg	F5545912 (*)	3,0 Kg	12 V AC	35 W		160°	RGB (Auto)	627 lm		F5645597		
F5350004	2,1 Kg	F5360005	5,4 Kg	12 V AC	REF Without lamp (Incandescence)/ REF sin lámpara (Incandescencia)						2PG 21 Ø11,7/15/18,6		
F5350015	2,0 Kg	F5360016	5,4 Kg	230 V AC	REF Without lamp (Incandescence)/ REF sin lámpara (Incandescencia)						2PG 16 Ø7/9/12		
F5510002	2,0 Kg	F5520003	5,4 Kg	12 V AC	REF Without lamp (LED)/ REF sin lámpara (LED)								

# 3 Dichroic ring/ Corona de 3 dicroicos

The crown of three dichroic spotlights is an **economical solution with great lighting power**, since the nozzle sits in the central part, which optimizes the amount of light that reaches the water. It is composed of three submersible, dichroic LED spotlights, with the choice of brass or plastic and white or RGB, which provide very good lighting.

La corona de tres focos dicroicos es una **solución económica y de gran poder de iluminación** gracias a que la boquilla ocupa la parte central, lo que optimiza la cantidad de luz que le llega al agua. Está compuesta por tres focos dicroicos de LED sumergibles, a elegir entre latón o plástico y blanco o RGB, mediante los que se obtiene una muy buena iluminación.



Dichroic ring

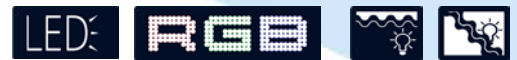
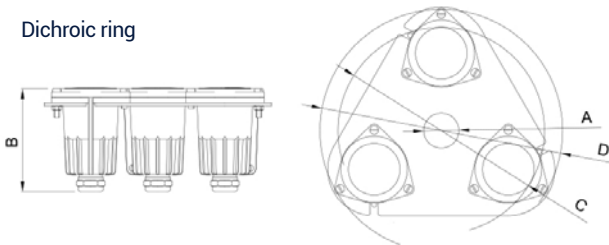

Certifications/ Certificaciones

IP68 CE

## 3 Dichroic lights ring/ Corona 3 focos dicróicos.

Details/ Detalles						Electrical data/ Datos eléctricos										
Reference/ Referencia	Weight/ Peso	Reference/ Referencia	Weight/ Peso	Conection/ Conexión A	Lenght/ Longitud				Lamp/ Lámpara					Life span/ Vida útil	Lamp/ Lámpara	Elect. Connection/ Conex. Elect.
					A (mm)	B (mm)	C (mm)	D (mm)	Voltage/ Voltaje	Power/ Potencia	Beam angle/ Ángulo	Color/ Color	Lumens/ Lúmens			
F5450141	1,46 Kg			½"	Ø22	103	Ø200	Ø240	12 V AC	6 W x3	38°	White 6500 K	1440 lm	30000 Hrs	F5642098	3PG 16-Ø6/9/12
F5455045	1,45 Kg								12 V AC	5 W x3	60°	RGB (Auto)	390 lm		F5642561	
F5456046	1,46 Kg	F5466047	3,25 Kg	1"	Ø34	103	Ø200	Ø240	12 V AC	5 W x3	60°	R + G + B	830 lm		F5642111	
F5450152	1,46 Kg	F5460153	3,25 Kg						12 V AC	6 W x3	38°	White 6500 K	1440 lm		F5642113	
F5455056	1,45 Kg	F5465057	3,24 Kg	1"	Ø34	103	Ø200	Ø240	12 V AC	5 W x3	60°	RGB (Auto)	390 lm		F5642114	
F5451052	1,45 Kg	F5461053	3,24 Kg						12 V AC	5 W x3	30°	R	1050 lm		F5642098	
F5453054	1,45 Kg	F5463055	3,24 Kg	1"	Ø34	103	Ø200	Ø240	12 V AC	5 W x3	30°	G	390 lm		F5642561	
F5454055	1,45 Kg	F5464056	3,24 Kg						12 V AC	5 W x3	30°	B	1050 lm		F5642111	
F5456057	1,46 Kg	F5466058	3,25 Kg	1 ¼"	Ø43	103	Ø223	Ø263	12 V AC	5 W x3	60°	R + G + B	830 lm		F5642113	
		F5460175	3,23 Kg						12 V AC	6 W x3	38°	White 6500 K	1440 lm		F5642114	
		F5465079	3,23 Kg	1 ¼"	Ø43	103	Ø223	Ø263	12 V AC	5 W x3	60°	RGB (Auto)	390 lm		F5642111	
F5456079	1,46 Kg	F5466071	3,25 Kg						12 V AC	5 W x3	60°	R + G + B	830 lm		F5642113	
F5450163	1,40 Kg	F5460164	3,20 Kg	1 ½"	Ø48,5	103	Ø200	Ø240	12 V AC	6 W x3	38°	White 6500 K	1440 lm		F5642114	
F5455067	1,40 Kg	F5465068	3,20 Kg						12 V AC	5 W x3	60°	RGB (Auto)	390 lm		F5642098	
F5451063	1,40 Kg	F5461064	3,20 Kg	1 ½"	Ø48,5	103	Ø200	Ø240	12 V AC	5 W x3	30°	R	1050 lm		F5642561	
F5453065	1,40 Kg	F5463066	3,20 Kg						12 V AC	5 W x3	30°	G	390 lm		F5642111	
F5454066	1,40 Kg	F5464067	3,20 Kg	1 ½"	Ø48,5	103	Ø200	Ø240	12 V AC	5 W x3	30°	B	1050 lm		F5642113	
F5456068	1,46 Kg	F5466069	3,25 Kg						12 V AC	5 W x3	30°	R + G + B	830 lm		F5642114	

Lighting/  
Iluminación



# WATER CURTAINS/ CORTINAS DE AGUA

Water curtain/ Cortina de agua Pag 81

Water wall/ Muro de agua Pag 82

Pool waterfalls/ Lámina de agua Pag 83



Water curtains/  
Cortinas de agua

**W**ater curtains have historically been very well accepted by urban landscapers and interior decorators, who have used them in many different ways, whether creating **attractive outdoor water walls** or as part of **interior water walls**.

We have always sought to give them a relaxing effect, and, as such, we can find interior water walls decorating various locations, such as offices, shopping centers, and even homes.

**L**as cortinas de agua históricamente han tenido una muy buena aceptación por parte de paisajistas urbanos y decoradores de interiores, quienes las han usado en sus diferentes formas, ya sea creando **attractivos muros de agua en exteriores** o formando una **pared de agua para interiores**.

Siempre hemos buscado en ellas el efecto relajante y por eso podemos encontrar las cortinas de agua decorando interiores de diversa índole como oficinas, centros comerciales e incluso nuestros propios hogares.

# Water curtain/ Cortina de agua

The out-flowing water runs continuously over the plastic sheet, which can even be fitted at an angle of 15° without the drop of water falling. A counterweight is fitted at the end of the plastic sheet so that the thread is taut at all times. It is **only used in indoor decorative fountains**, small installations or large shopping centres to decorate stairways or suchlike.

El agua se desliza por una lámina de plástico llegando incluso a poder colocar esta con una inclinación de 15° sin que la gota caiga. Al final de la lámina de plástico se coloca un contrapeso para que el hilo esté en todo momento tenso. Únicamente se utiliza en fuentes de interior, bien en pequeñas instalaciones o bien en grandes centros comerciales aprovechando huecos de escalera o similares.

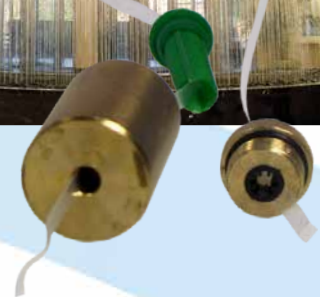
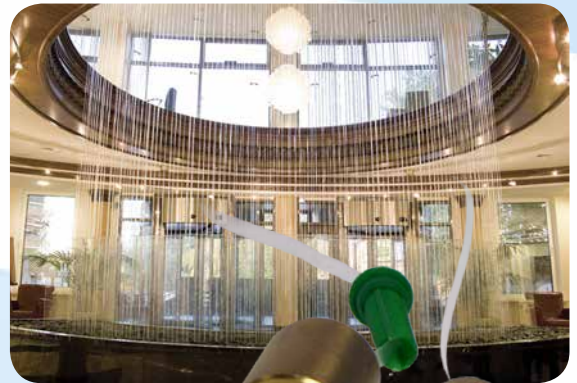

ONSTOCK

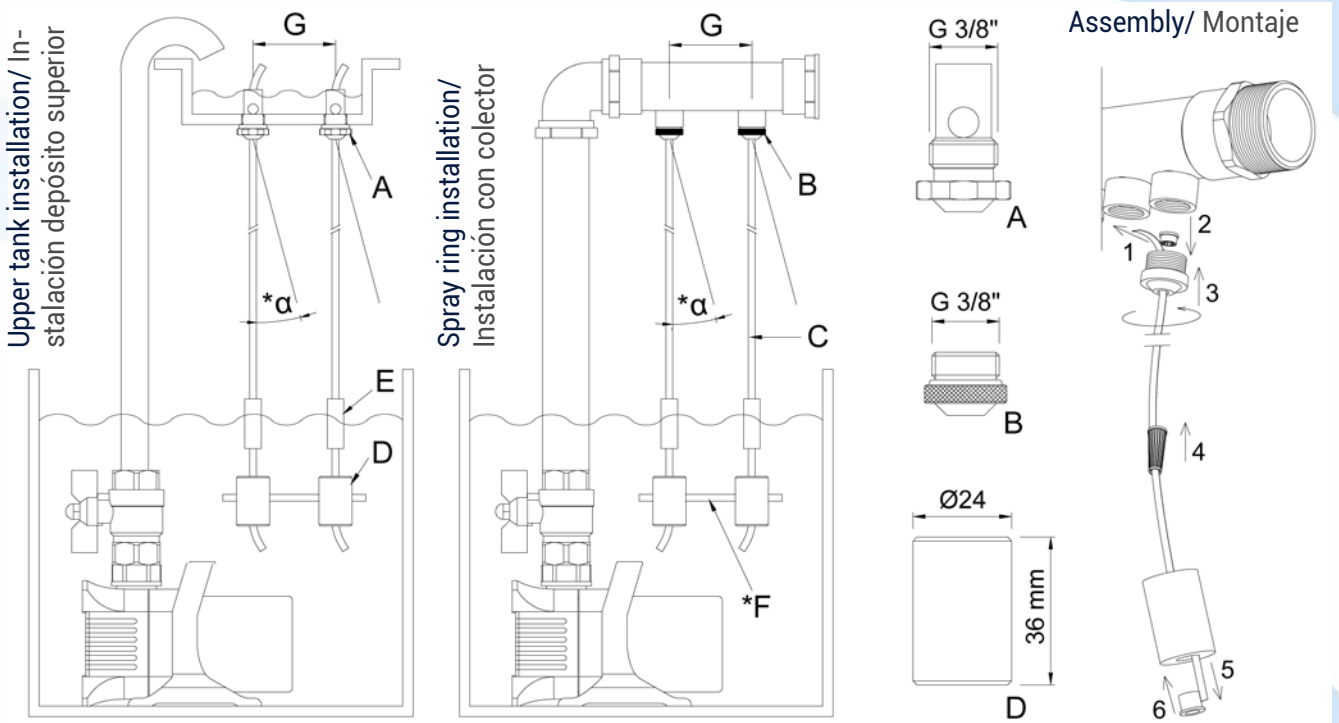

(\*)  $\alpha$  Max 15°. Use lace spacer/ Utilizar espaciador de hilo F

	Tank nozzle & Clunch cap/ Tobera para depósito & Tapón A	Spray ring nozzle & Clunch cap/ Boquilla para colector & Tapón B	Mylar lace roll/ Rollo hilo milar C		Counterweight & Clunch cap/ Contrapeso & Tapón D	Splash suppresor/ Antisalpicadura E
Reference/ Referencia	F2720013	F2723804	F2720068	F2720079	F2720024	F2720046
Dimensions/ Dimensiones	Flow/ Caudal 0,5 l/min		Lenght/ Longitud		-	-
	Outlet Diameter/ Diametro salida Ø5 mm		75 m	100 m	-	-
	Min. Distance/ Distancia min. G	Width and thickness/ Ancho y espesor		-	-	
	30 mm	25 mm	4 x 1 mm		-	-

Water curtains/  
Cortinas de agua

# Water wall/ Muro de agua

The water wall is a versatile product that works both as an interior fountain, thanks to its silent operation, as well as for exterior fountains, thanks to its high wind resistance. It is an easily installable fountain kit, ideal for decorating interiors and vertical gardens. The water jets can slide like layers on different surfaces. Furthermore, this water wall is a low energy consumption.

El muro de agua es un producto versátil que vale tanto para fuentes de interior, gracias a su silencioso funcionamiento, como para fuentes de exterior debido a su elevada resistencia al viento. Es un kit de fuente fácilmente instalable e idóneo para la decoración de interiores y de jardines verticales ya que los chorros de agua se pueden deslizar en forma de lámina por diferentes superficies. Además, este muro de agua o pared de agua es una fuente de bajo consumo energético.

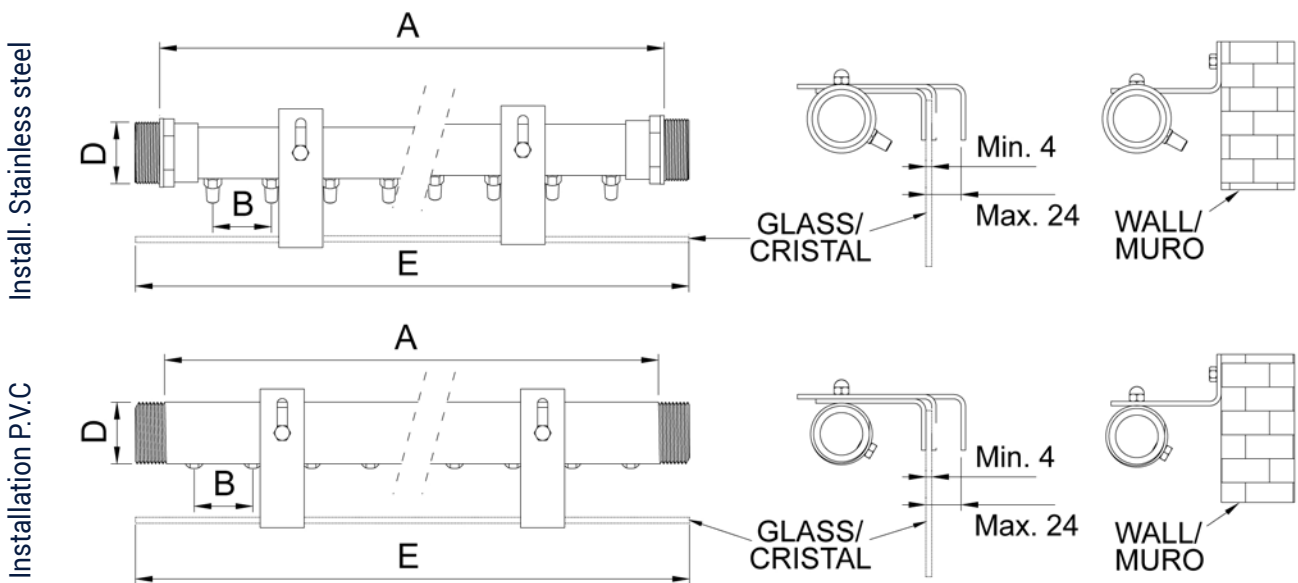

Reference/ Referencia	F2721003	F2721014	F2721025	F2721104	F2721115	F2721126
Length/ Longitud A (mm)	1000	2000	3000	1000	2000	3000
No. nozzles/ Nº de toberas	24	48	72	24	48	72
Nozzles diameter/ Diam. toberas	Ø6 mm					
Space between outlets/ Entre salidas B (mm)	40					
Connection/ Conexión D BSP	G 1 ¼" M	G 2" M		G 1 ¼" M	G 2" M	
Glass min. length/ Longitud min. cristal E (mm)	1040	2040	3040	1040	2040	3040
Material/ Material	Stainless steel - Brass/ Acero inox. - Latón			P.V.C - Brass/ P.V.C - Latón		
Weight/ Peso (kg)	1,58	4,35	6,44	1,45	4,00	5,96
Flow/ Caudal (l/min)	48	103	155	48	103	155
Pressure/ Presión (m.c.a)	0,10	0,12	0,15	0,10	0,12	0,15



# Pool waterfall/ Lámina de agua

The **pool waterfall weir** is a product specially designed for creating **swimming pool waterfalls**, for outdoor and indoor areas, thanks to its harmonious and relaxing sound. This **waterfall nozzle made in Stainless steel, available in different sizes, and as option LED strip White or RGB stylishly integrated\***, will produce a **laminar fall of water** easily installable and easy to maintain, thanks to its design ideal to bring style to any pool waterfall or garden fountain and giving a luxurious touch, due to this **pool waterfall weir**.

Las cascadas para piscinas son un producto idóneo para exterior o zonas de interior gracias a su sonido armonioso y relajante. Se trata de una caída de agua en forma de cascadas fácilmente instalable y de sencillo mantenimiento que, gracias a su diseño, produce cascadas artificiales para piscinas o fuentes que aportarán estilo a sus proyectos, dándole un toque lujoso. Fabricada en acero inoxidable, disponibles en varios tamaños e iluminación opcional mediante una tira LED Blanca o RGB elegantemente integrada\*, encontrarás en esta boquilla la solución ideal para darle un toque especial a su casa o jardín gracias a estas cascadas para piscinas.



Measures scheme/ Esquema de medidas

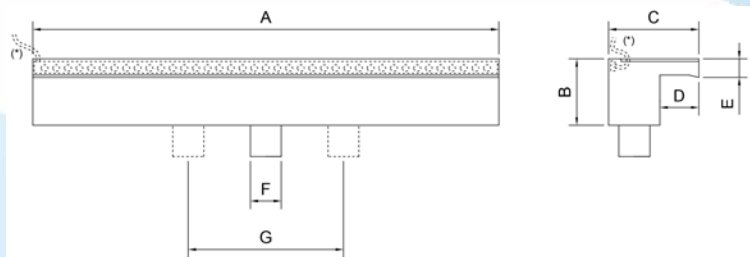

**ON STOCK**

**AISI 304** **AISI 316**

**LED** **RGB**

Reference/ Referencia	F2722004	F2722026	F2722015	F2722037
Length/ Longitud	A (mm)	600		900
	B (mm)	85		85
	C (mm)	116		116
	D (mm)	50		50
	E (mm)	24		24
Inlet connection/ Conexión F	G1" BSP/NPT F/H		2 x G1" BSP/NPT F/H	
Length/ Longitud G (mm)			300	
Material / Material	Stainless steel (AISI-304) / Acero inoxidable (AISI-304)	Stainless steel (AISI-316) / Acero inoxidable (AISI-316)	Stainless steel (AISI-304) / Acero inoxidable (AISI-304)	Stainless steel (AISI-316) / Acero inoxidable (AISI-316)
Weight/ Peso	2,3 kg		3,4 kg	
Max. height advisable/ Max. Altura recomendable	0,75 m		0,90 m	
P (m.c.a.)	0,6		0,6	
Q (l/min)	40-65		80-120	

## Lighting/ Iluminación

Reference/ Referencia	F2722184	F2722588	F2722195	F2722599
SMD LED Lighting (*)/ Iluminación LED SMD	White/ Blanco	RGB with remote control/ RGB con control remoto	White/ Blanco	RGB with remote control/ RGB con control remoto
Voltage/ Voltaje	12 V AC (*)	12 V AC (*)	12 V AC (*)	12 V AC (*)
Power/ Potencia	2 W	3,4 W	4,2 W	4,6 W
Length cable/ Longitud cable	10 m	5 m	10 m	5 m
Length/ Longitud A (mm)	600		900	

(\*) Transformer included 240V-12V/ Incluyen transformador 240V-12V

Water curtains/  
Cortinas de agua

# SPRAY RINGS/ COLECTORES DE AGUA

Circular fountain ring/ Colectores circulares Pag 85

Polygonal fountain ring/ Colectores poligonales Pag 86

Articulated fountain ring/ Colectores articulados Pag 87

Jet pipe stocks/ Hileras de chorros Pag 88



Spray rings/  
Colectores

**B**y working closely with our customers for many years, we have been able to **develop fountain spray rings that meet the needs of all architectural fountains**, creating almost **any geometrical shape**: circle patterns of any diameter, a number of pipe stocks or rows of water jets, or articulated polygons that allow multi-sided patterns to be created in any shape and with any number of sides (the geometrical shape can be adapted to the geometry of the water fountain basin.) In all cases, not only the diameter but also the number of jets and inlets can be specified for all fountain rings.

**E**l trabajo codo con codo con nuestros clientes nos ha permitido a lo largo de los años **desarrollar colectores adaptados a las necesidades de todas las fuentes ornamentales**, con prácticamente **cualquier forma geométrica**, circulares sea cual sea el diámetro, hileras o filas de chorros de agua, poligonales articulados que permiten crear polígonos de la forma y número de lados que necesitemos, (pudiendo adaptar su forma a la geometría del vaso de la fuente de agua) definiendo en todos los casos el diámetro así como el número de chorros y entradas para cada colector.



# Circular fountain ring/ Colectores circulares

Circular fountain rings are **manufactured as a single part** and do not require any joints when fitting. They are made of **stainless steel piping** in two diameter sizes:

- **Ø 35 mm and 4 connections x 1" M**
- **Ø 54 mm and 4 connections x 1 1/2" M**

Fountain rings measuring Ø35 mm are available in 0.75 m and 1.00 m diameter sizes, while Ø 54 mm rings can be 1.00 m or 1.50 m. The outlets used are brass end fittings with 3/8" F or 1/2" F gas threads, which allows jet pipes measuring up to 1/2" to be installed.

**The number of outlets you choose can be either a pre-fabricated standard or made-to-order.** Contact us and we will study the best alternative for you.

Los anillos o colectores circulares están **fabricados en una pieza**, no necesitan uniones para ser montados. Se fabrican con **tubería de acero inoxidable** en dos diámetros:

- **De Ø35 mm y 4 conexiones de 1" M**
- **De Ø54 mm y 4 conexiones de 1 1/2" M**

Los colectores de Ø35 mm están disponibles en diámetros de 0,75 m y de 1,00 m, mientras los colectores de Ø54 mm, pueden ser de 1,00 m ó 1,50 m. Tienen como salidas, terminales de latón con rosca gas de 3/8" H ó 1/2" H, lo que permite instalar toberas de hasta 1/2".

**Puede optar por el número de salidas prefabricado o solicitar un número de salidas personalizado.** Contacte con nosotros y estudiaremos una alternativa.

**ON STOCK**



Dimensions/  
Dimensiones

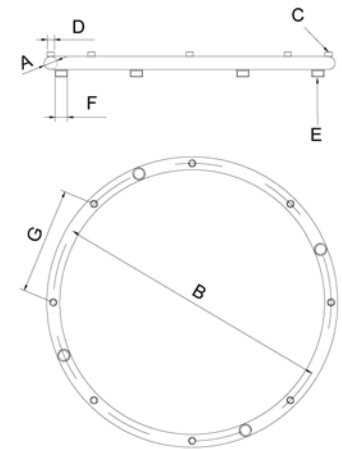

Reference/ Referencia	F3110815	F3111614	F3111221	F3112424	F3120816	F3121615	F3121222	F3122425	F3143226	F3144824	F3144835	F3147232	F3132426	F3133225	F3133236	F3134834	F3150819	F3151629	F3151631	F3152441
Measures/ Medidas	Ø35								Ø54											
Pipe diameter/ Diámetro tubo A (mm)	Ø35								Ø54											
Ring diameter/ Diámetro colector B (mm)	Ø750	Ø1000	Ø750	Ø1000	Ø750	Ø1000	Ø1000	Ø1000	Ø1500	Ø1000	Ø1500	Ø1000	Ø1500	Ø750	Ø1000	Ø1500	Ø750	Ø1000	Ø1500	Ø1500
No. outlets/ N° salidas C	8	16	12	24	8	16	12	24	32	48	48	72	24	32	32	48	8	16	16	24
Outlet diameter/ Diámetro salidas D	G3/8" F/H				G½" F/H				G3/8" F/H				G½" F/H				G1" F/H			
No. inlets/ N° entradas E	4																			
Connection/ Conexión F	G1" M BSP-NPT								G1½" M BSP											
Space between outlets/ Entre salidas G (mm)	287	146	259	131	287	146	259	131	98	73	98	65	131	98	147	98	287	195	293	196

Further information at [www.saferain.com](http://www.saferain.com) | Más información en [www.saferain.com](http://www.saferain.com)



# Polygonal fountain ring/ Colectores poligonales

Polygon-shaped fountain ring is made of stainless steel piping in two diameter sizes:

- Ø 35 mm and 12 connections x 1 1/4" F
- Ø 54 mm and 12 connections x 2" F

The sides are joined together using a special 150° "T" joint, forming a 12-sided polygon. Both diameter sizes are available with brass end fittings featuring 3/8" FH, 1/2" F, and 1" F gas threads. For Ø 54, they are also available with 2" F outlets. **This fountain ring must be used when diameter sizes of more than 1 m are required.**

All our water manifolds can be manufactured on demand and according to the design of the desired water feature.

Los colectores poligonales están fabricados con tubería de acero inoxidable en dos diámetros:

- De Ø35 mm y 12 conexiones de 1-1/4" H
- De Ø54 mm y 12 conexiones de 2" H

Las uniones de los lados se realizan mediante una "TE" especial con un ángulo de 150° y unidos entre si, forman un polígono de 12 lados. Ambos diámetros están disponibles con salidas de latón con rosca gas de 3/8" H, 1/2" H, o 1" H. En Ø54, también disponible con salidas de 2" H. **Es necesario recurrir a este tipo de colector cuando se desea conseguir diámetros superiores a 1m.**

Todos los colectores se pueden fabricar bajo demanda y según diseño de la fuente.



Dimensions/ Dimensiones

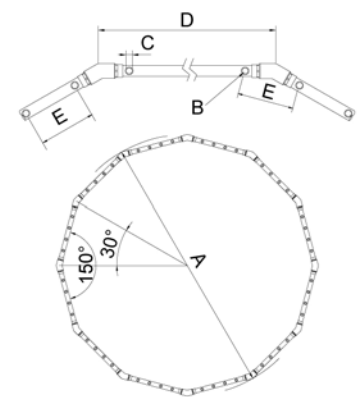

PIPE/ TUBO Ø 35 mm Connection G1 1/4" F/H BSP	Reference/ Referencia	F3201423	F3202132	F3202841	F3200332	F3211424	F3210221	F3212842	F3213022	F3221425	F3222123	F3222832	F3223023
	Measures/ Medidas												
Ring diameter/ Diámetro colector A (cm)		Ø140	Ø210	Ø280	Ø300	Ø140	Ø210	Ø280	Ø300	Ø140	Ø210	Ø280	Ø300
No. outlets/ N° salidas B		24	36	48	36	24	24	48	24	24	24	36	24
Outlet diameter/ Diámetro salidas C		G3/8" F/H				G1/2" F/H				G1" F/H			
Side length/ Long. lado D (cm)		36	54	72	78	36	54	72	78	36	54	72	78
Space between outlets/ Entre salidas E (cm)		11	18	18	26	18	27	18	39	11	27	24	39

PIPE/ TUBO Ø 54 mm Connection G2" F/H BSP	Reference/ Referencia	F3262735	F3263646	F3264557	F3265468	F3271825	F3272725	F3273636	F3270532	F3281826	F3283637	F3284559	F3285461
	Measures/ Medidas												
Ring diameter/ Diámetro colector A (cm)		Ø270	Ø360	Ø450	Ø540	Ø180	Ø270	Ø360	Ø500	Ø180	Ø360	Ø450	Ø540
No. outlets/ N° salidas B		36	48	60	72	24		36		24	36	60	72
Outlet diameter/ Diámetro salidas C		G3/8" F/H				G1/2" F/H				G1" F/H			
Side length/ Long. lado D (cm)		70	93	116	140	47	70	93	129	47	93	116	140
Space between outlets/ Entre salidas E (cm)		23	23	23	23	23	35	31	43	23	31	23	23

# Articulated manifolds/ Colectores articulados

**A**rticulated polygon-shaped water manifolds made from stainless steel with brass connectors. They are made of 35 mm diameter piping with 1¼" F connectors. Their outlets are brass end fittings with 3/8" F or 1/2" F gas threads.

They are designed not only to **create diverse water distribution patterns**, but also to form shapes that are the same as the fountain basins and to produce different water sculptures.

All our water manifolds can be custom-made according to the design of the desired water feature.

**C**olectores poligonales articulados fabricados en acero inoxidable y conexiones de latón. Se fabrican en tubería de 35 mm de diámetro y conexiones de 1¼" H, y tienen como salidas terminales de latón con rosca gas 3/8" H ó 1/2" H.

Están diseñadas para **realizar diversas estructuras de reparto de agua** y conseguir formas de igual manera a los vasos de las fuentes, así como conseguir diferentes esculturas de agua.

Todos los colectores se pueden fabricar bajo demanda y según diseño de la fuente



Dimensions/  
Dimensiones

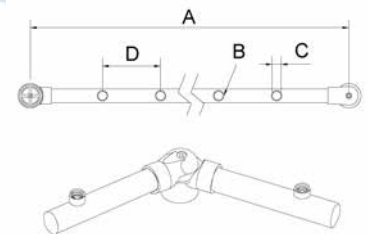

PIPE/ TUBO Ø 35 mm Connection G1¼" F/H BSP	Reference/ Referencia	F3720622	F3720925	F3721228	F3721522	F3722128	F3721544	F3721847	F3722141	F3730623	F3730926	F3731229	F3731523	F3732129	F3731545	F3731848	F3732142
	Measures/ Medidas																
Side length/ Longitud lado A (cm)		36	54	72	90	126	180	216	252	36	54	72	90	126	180	216	252
No. outlets/ N° salidas B		6	9	12	15	21	15	18	21	6	9	12	15	21	15	18	21
Outlet diameter/ Diámetro salidas C		G3/8" F/H						G½" F/H									
Space between outlets/ Entre salidas D (cm)		6	6	6	6	6	12	12	12	6	6	6	6	6	12	12	12

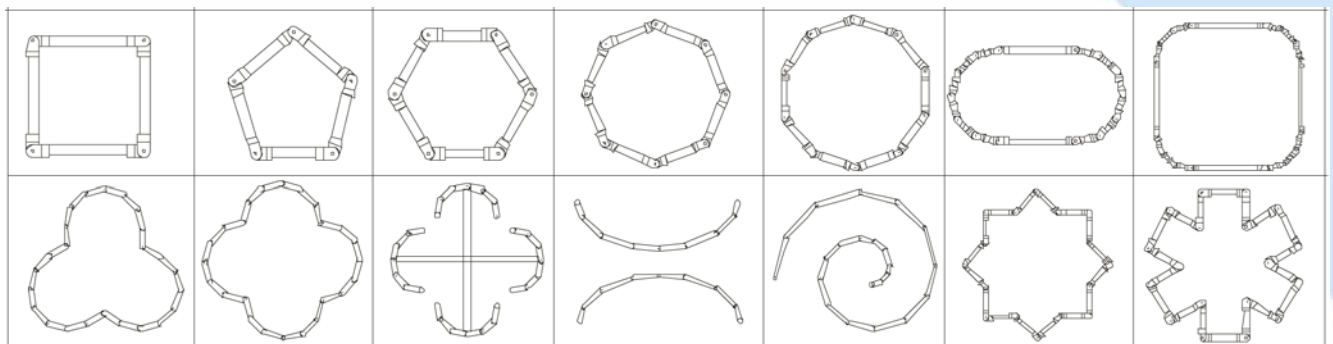

Spray rings/  
Colectores

# Jet pipe stocks/ Hileras de chorros

Jet pipe stocks are made of stainless steel with brass connectors. They are manufactured in two diameter sizes:

- Ø 35 mm and 1 1/4" m connectors
- Ø 54 mm and 2" m connectors

The outlets for both diameter sizes are made from brass with 3/8" F, 1/2" F or 1" F gas threads, or 2" F only for those with a 54 mm diameter. In very long water fountains, several pipe stocks can be joined together with "T" joints and used as water inlets.

All our pipe stocks can be custom-made according to the design of the desired water feature.

Las hileras de chorros están fabricadas en acero inoxidable y conexiones de latón. Se fabrican en dos diámetros de tubería:

- De Ø35 mm y conexiones de 1 1/4" M
- De Ø54 mm y conexiones de 2" M

Las salidas para ambos diámetros son de latón con rosca gas de 3/8" H, 1/2" H ó 1" H y de 2" H solo para los de diámetro 54 mm. En fuentes muy largas, se pueden unir varias hileras mediante TES y usarlas como entradas de agua.

Todos las hileras se pueden fabricar bajo demanda y según diseño de la fuente



Dimensions/  
Dimensiones

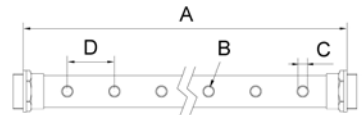

PIPE/ TUBO Ø 35 mm Connection G1 1/4" M BSP	Reference/ Referencia	F3820926	F3821523	F3821545	F3822142	F3830927	F3831221	F3832121	F3831546	F3831849	F3841222	F3842122	F3841841	F3842144
	Measures/ Medidas													
	Side length/ Longitud lado A (cm)	54	90	180	252	54	72	126	180	216	72	126	216	252
	No. outlets/ N° salidas B	9	15	15	21	9	12	21	15	18	12	21	18	21
	Outlet diameter/ Diámetro salidas C	G3/8" F/H				G1/2" F/H				G1" F/H				
	Space between outlets/ Entre salidas D (cm)	6	6	12	12	6	6	6	12	12	6	6	12	12

PIPE/ TUBO Ø 54 mm Connection G2" M BSP	Reference/ Referencia	F3880629	F3881529	F3881542	F3881845	F3890621	F3891226	F3892127	F3891846	F3892149	F3910926	F3911523	F3912129	F3911545	F3912142
	Measures/ Medidas														
	Side length/ Longitud lado A (cm)	36	90	180	252	36	72	126	216	252	54	90	126	180	252
	No. outlets/ N° salidas B	6	15	15	21	6	12	21	18	21	9	15	21	15	21
	Outlet diameter/ Diámetro salidas C	G3/8" F/H				G1/2" F/H				G1" F/H					
	Space between outlets/ Entre salidas D (cm)	6	6	12	12	6	6	6	12	12	6	6	6	12	12



# FOUNTAIN ACCESSORIES/ ACCESORIOS PARA FUENTES

Hydraulic accessories/ Accesorios hidráulicos Pag 90

Electrical accessories/ Accesorios eléctricos Pag 96

Junction boxes/ Cajas de conexión Pag 100

Water pumps/ Bombas de agua Pag 102



**O**ur fountain accessories are **specifically designed to make installing, adjusting and maintaining a water feature fountain easier.** Our bespoke solutions are perfect for all types of water fountains. These fountain accessories make up the rest of the catalog of products necessary for the design and installation of an architectural fountain. **You will be able to find any material that you need for the construction of your architectural water feature,** ranging from a simple flow stabilizer or bottom water intakes to level sensors or our complex bespoke control panels.

**N**uestros accesorios para fuentes están **específicamente diseñados para facilitar la instalación, el reglaje/ajuste así como su mantenimiento.** Aportamos soluciones adaptadas para todos los tipos de fuentes de agua. Estos accesorios para fuentes completan todo el catálogo de productos necesarios para el diseño e instalación de una fuente ornamental. **Podrá encontrar cualquier material necesario para la construcción de su fuente ornamental,** desde un sencillo estabilizador de flujo o las tomas de fondo hasta las sondas de nivel o nuestros complejos cuadros eléctricos creados a medida.

# Flow stabilizer/ Estabilizador de flujo

Flow stabilizers are used to smooth out water turbulence caused by the water pump forcing the water through pipes and other components such as elbows and tees, etc. This component is fitted just before the fountain nozzle to ensure that the water running through the nozzle is flowing in the most laminar way possible, leading to a **more crystal-line jet with greater height performance**.

Some nozzles are already fitted with their own flow stabilizer, although this is redundant to some extent, as achieving the best possible water flow quality always allows this pre-installed component to behave optimally.

El estabilizador de flujo se utiliza para conseguir calmar las turbulencias del agua cuando ésta es impulsada por la bomba de agua a través de tuberías y piezas, como codos, tees u otras. Esta pieza se coloca justo antes de la boquilla para conseguir que el agua que llega a la tobera esté en el régimen más laminar posible, lo que provoca un **chorro más cristalino y mejor rendimiento en altura**.

Algunas boquillas ya llevan incorporado su propio estabilizador de flujo, aunque en modo alguno es redundante este hecho, pues conseguir una mayor calidad del régimen de agua siempre hace que su comportamiento sea más óptimo.



Reference/ Referencia	F7453811	F7451212	F7451019	F7451515
Connection/ Conexión A BSP-NPT	G3/8" M	G1/2" M	G1" M	G1 1/2" M
Length/ Longitud B (mm)	19,5	26,6	55,2	74,5
Length/ Longitud C (mm)	Ø20	Ø23	Ø40	Ø57
Weight/ Peso (g)	19	28	107	290
Material/ Material	Brass - Polyethylene/ Latón - Polietileno			

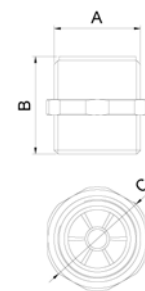

Reference/ Referencia	F7451559	F7452055
Connection/ Conexión A BSP	G1 1/2" F/ H	G2" F/ H
Connection/ Conexión B BSP	G1 1/2" M	G2" M
Length/ Longitud C (mm)	74,5	85,5
Length/ Longitud D (mm)	55,5	63,4
Length/ Longitud E (mm)	Ø63	Ø86
Weight/ Peso (g)	582	1046
Material/ Material	Brass - Polyethylene/ Latón - Polietileno	

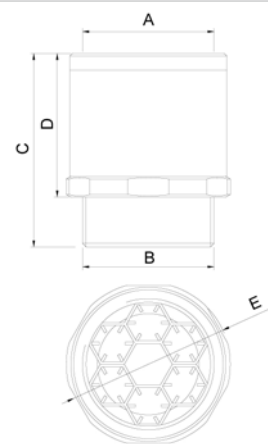

# Adapter BSP-NPT/ Adaptador BSP-NPT

**B**SP-NPT adapters are transition pieces that convert a BSP connection into NPT solving this incompatibility in those cases where it occurs. Manufactured in brass with the usual quality of SAFE RAIN products.

**L**os adaptadores BSP-NPT son piezas de transición y convierten una conexión BSP en NPT solventando esta incompatibilidad en aquellos casos donde se presente. Fabricados en latón, y con la calidad habitual de los productos de SAFE RAIN.

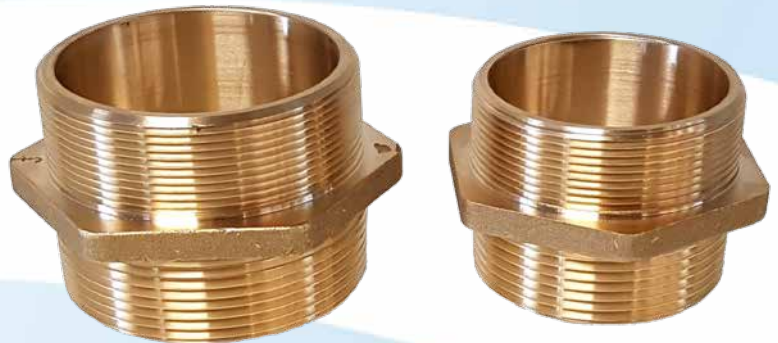

Reference/ Referencia	F7380257	F7380303
Connection/ Conexión A BSP	2½"	3"
Connection/ Conexión B NPT	2½"	3"
Length/ Longitud C (mm)	60	67
Length/ Longitud D (mm)	84	97
Length/ Longitud E (mm)	95	110
Weight/ Peso (kg)	0,44	0,83
Material/ Material	Brass/ Latón	

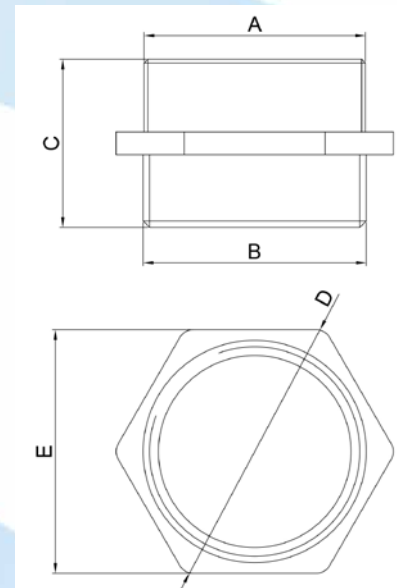

## Compact rainbow jet/ Arcoiris compacto

**AISI 304**

**LED**

**RGBW**

- Diseño compacto.
- LED 10W RGBW integrado.
- Con colores extraordinariamente brillantes para iluminar uniformemente el chorro de agua en toda su longitud.
- Instalación sencilla.
- Compact design.
- Built-in 10W RGBW LED.
- With extraordinarily bright colors to uniformly illuminate the water jet along its entire length.
- Easy installation.





# Ball joints/ Rótulas

**B**all joints are used to achieve the desired inclination of water jets in architectural fountains. On occasions the installation of hydraulic components does not achieve the vertical orientation or the angle necessary for the fountain nozzles to operate correctly. There are three types of articulated joints:

**L**as rótulas se utilizan para conseguir la inclinación del chorro de agua deseado en una fuente ornamental, en ocasiones, en el montaje de la instalación hidráulica no se consigue la verticalidad o ángulo necesario para el correcto funcionamiento de las toberas. Las rótulas pueden ser de tres tipos:

- **360° around** an axis and 19° crosswise to this axis.
- A **sphere or ball type** that allows fountain nozzles to be perfectly adjusted to vertical, or parabolic water jets to be achieved
- **Adjustable flange type.** Less volume and weight but less angle of inclination.
- De **360° alrededor de un eje** y 19° transversalmente a este eje.
- Tipo **esférica o bola** que permiten ajustar la perfecta verticalidad de las boquillas para fuentes o conseguir chorros de agua parabólicos
- Tipo **brida ajustable**, menor volumen y peso pero con menos ángulo de inclinación.

**ON STOCK**



Full rotation/ Giro completo

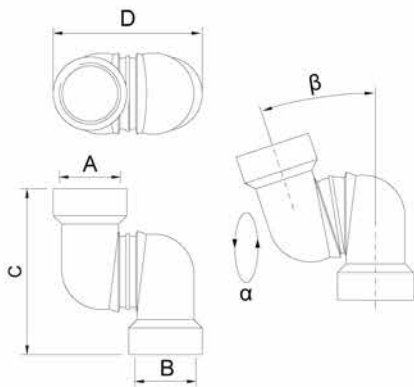

Flange/ Brida

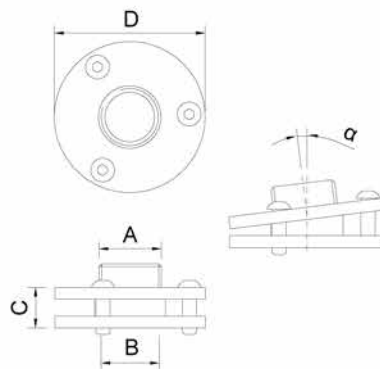

Ball joint/ Esférica

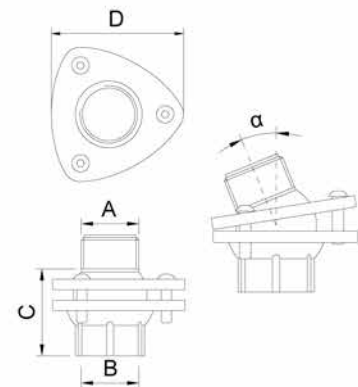

Reference/ Referencia	F7401036	F7403411	F7403073	F7401058	F7401554	F7402059	F7402555	F7403051
Connection/ Conexión A BSP	G 1" F/H	G ¾" M	G 3" M	G 1" M	G 1½" M	G 2" M	G 2½" M	G 3" M
Connection/ Conexión B BSP	G 1" F/H	G ¾" F/H	G 3" F/H	G 1" F/H	G 1½" F/H	G 2" F/H	G 2½" F/H	G 3" F/H
Length/ Longitud C (mm)	91	16	34	50	90	87	102	120
Length/ Longitud D (mm)	82	62	146	76	95	116	140	163
Angle/ Ángulo $\alpha$	360°	7°	7°	22°	23°	23°	20°	20°
Angle/ Ángulo $\beta$	15°	-	-	-	-	-	-	-
Type/ Tipo	Full rotation/ Giro completo	Flange/ Brida	Flange/ Brida	Ball joint/ Esférica	Ball joint/ Esférica	Ball joint/ Esférica	Ball joint/ Esférica	Ball joint/ Esférica
Straighteners/ Centrador	✘	✘	✘	✔	✔	✔	✔	✔
Weight/ Peso (g)	0,44	0,22	2,20	0,80	1,40	2,04	3,10	4,65
Material/ Material	Brass/ Latón							

# Basin drain/ Toma de fondo

**B**asin drain are installed during construction at the bottom of the basin or fountain of the architectural water feature for **drainage purposes or for the aspiration of the pump unit.**

Basin drain can have 2"F or 3"F brass grates or a 2" screw cap. Intakes with caps can be used for the assembly of an adjustable overflow to maintain the water level of architectural water features. These can be disassembled when it is necessary to empty the water fountain.

**L**as tomas de fondo van empotradas en la obra civil en el fondo del vaso o pileta ornamental de la fuente de agua para **desagüe de ésta o aspiración del grupo de bombeo.**

Las tomas de fondo pueden ser con rejilla de latón en 2"H ó 3"H o con tapón roscado de 2". Las tomas con tapón se pueden usar para montar un rebosadero regulable que mantenga el nivel de agua de la fuente ornamental y desmontarlo cuando se quiera vaciar ésta.



F7462001



F7463002



F7482003

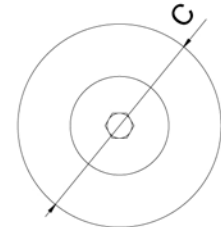
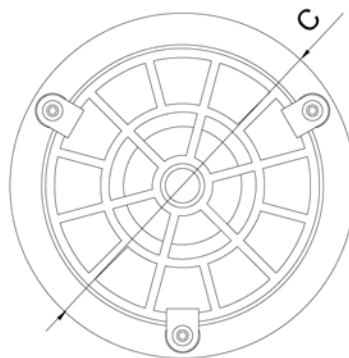
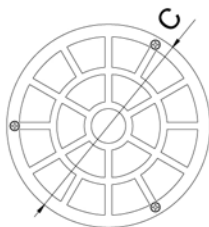
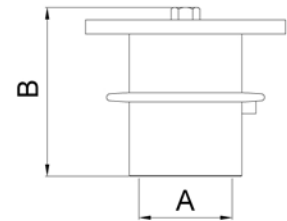
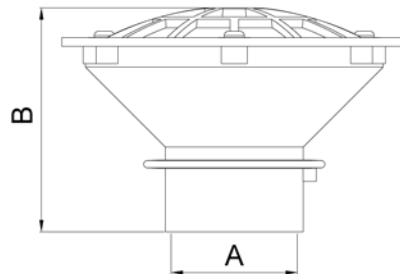
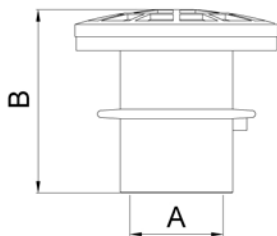

Reference/ Referencia	F7462001	F7463002	F7482003
Connection/ Conexión A BSP	G 2" F/ H	G 3" F/ H	G 2" F/ H
Length/ Longitud B (mm)	118	156	110
Length/ Longitud C (mm)	Ø132	Ø240	Ø132
Weight/ Peso (g)	1,93	4,50	2,50
Material/ Material	Brass/ Latón		

# Overflow/ Rebosadero

**A**djustable overflows maintain the maximum level of water inside the basin or fountain of the architectural water feature; they can be set to adjust the water to the desired height, which can either be between 30 and 50 cm or 50 and 90 cm. Optional 2" basin drain so that the overflow can be dismantled if the water fountain needs to be emptied.

**L**os rebosaderos mantienen el nivel máximo de agua dentro del vaso o pileta de la fuente ornamental, son regulables para ajustarse a la altura deseada, a elegir entre 30 a 50 cm ó 50 a 90 cm. Opcional con toma de fondo de 2" para poder desmontar el rebosadero en caso de querer vaciar la fuente de agua.

ON STOCK

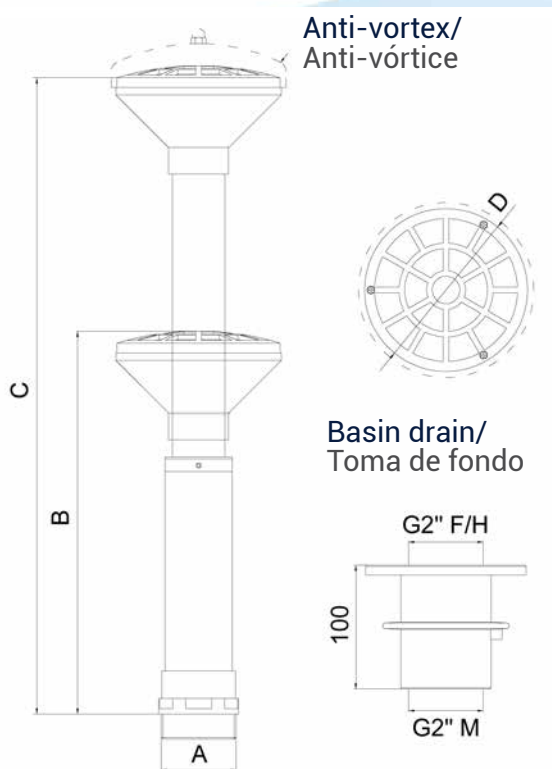

Reference/ Referencia	F7432007	F7432018	F7432029	F7432031	F7433008	F7433019	F7472002	F7472013	F7472024	F7472035
Connection/ Conexión A BSP	G 2" M	G 2" M	G 2" M	G 2" M	G 3" M	G 3" M	G 2" M	G 2" M	G 2" M	G 2" M
Length/ Longitud B (mm)	300	500	300	500	300	500	300	500	300	500
Length/ Longitud C (mm)	500	900	500	900	500	900	500	900	500	900
Length/ Longitud D (mm)	Ø132	Ø132	Ø139	Ø139	Ø240	Ø240	Ø132	Ø132	Ø139	Ø139
Weight/ Peso (g)	2,15	2,71	2,05	2,61	15,00	16,30	4,00	4,56	3,90	4,46
Material/ Material	Stainless steel - Brass/ Acero inoxidable - Latón									
With anti-vortex/ Con antivortice	✗	✗	✓	✓	✗	✗	✗	✗	✓	✓
With basin drain/ Con toma de fondo	✗	✗	✗	✗	✗	✗	✓	✓	✓	✓

Further information at [www.saferain.com](http://www.saferain.com) | Más información en [www.saferain.com](http://www.saferain.com)



# Support/ Soportes

## Support for manifolds

These accessories are used to fix the water manifolds in place without it being necessary to fix them directly over the water intakes. This spreads the load over several points of the manifold or pipe stock and ensures that they are properly horizontal in relation to the ground. Robust, made of stainless steel and adjustable in height to be adaptable to the dimensions that normally have fountain ponds, and the correct leveling.



## Soporte para colector

Con estos accesorios conseguimos fijar los colectores de agua sin necesidad de sujetarlos directamente sobre las tomas de agua y repartir el peso en varios puntos del colector o hilera, así como su correcta nivelación horizontal respecto al suelo y orientación de las toberas. Robustos, fabricados en acero Inoxidable AISI 304 y regulables en altura para ser adaptables a las dimensiones más habituales de las fuentes y la correcta nivelación.

## Support for Lights

Accessory designed to fix the spotlights in the proper location inside the pond for optimum illumination of the different water effects. We offer 2 models, one adjustable in height and fixed to the bottom of the pond, and another one of direct fixation to the collector pipe. This system is economical and avoids intervening in the pond slab.



## Soporte para focos

Accesorio diseñado para fijar los focos en la ubicación adecuada dentro del estanque para la óptima iluminación de los diferentes efectos de agua. Ofrecemos 2 modelos uno regulable en altura y fijación al fondo del estanque, y otro de fijación directa a la tubería del colector. Este último es económico y evita intervenir en el la losa del estanque.



**AISI 304**

		Spray rings support/ Soporte colectores		Lightfixture support/ Soporte para focos		Lightfixture support to spray rings/ Soporte focos a colectores	
Reference/ Referencia		F7353358	F7353549	F7352008		F3110005	F3110016
Length/ Longitud	A (mm)	Ø35	Ø54	M6		Ø35	Ø54
	B (mm)	250		250		222	
	C (mm)	450		450		235	
	D (mm)	20		20			
Weight/ Peso (kg)		1,15	1,30	1,15		0,38	0,43
Material/ Material		Stainless steel AISI - 304 - Brass/ Acero inoxidable AISI - 304 - Latón				Stainless steel AISI - 304/ Acero inoxidable AISI - 304	

# RGB or RGBW DMX controllers/ Controlador RGB ó RGBW DMX

The RGB LED or RGBW LED spotlights from a fountain are managed by RGB or RGBW controllers. These controllers can achieve hundreds of thousands of colors by the basic color addition method (RGB or RGBW). Mixing a part or the total of each basic color all other colors are obtained. They can work two ways: autonomously, - with already programmed output sequences-, or in a DMX network, as a dirigible channel of the system, with DMX in- and output. SAFERAIN offers 3 models depending on the installation and type of LED spotlight. All 3 are common anode (V+) and 3 or 4 colors (V-).

Mediante los controladores RGB o RGBW se gobiernan los focos LED RGB o LED RGBW de una fuente. Estos controladores pueden conseguir cientos de miles de colores por el método de adición de colores básicos (RGB o RGBW). Mezclando una parte o el total de cada color básico se obtienen el resto. Pueden funcionar de dos maneras: de manera autónoma, tienen secuencias de salidas programadas, o en una trama DMX como canal direccionable del sistema con entrada y salida DMX. SAFERAIN dispone de 3 modelos en función de la instalación y del tipo de foco LED. Los 3 son de ánodo común (V+) y 3 o 4 colores (V-).



## Technical details/ Detalles técnicos

Reference/ Referencia	F6325356	F6324221	F6324232
Type/ Tipo	RGBW	RGB	RGB
Input voltage/ Tensión entrada	DC 7V - DC 24V	DC 12V - DC 24V	DC 5V - DC 24V
Max. load current/ Corriente salida	5A/ch x4 Max. 20A	8A/ch x3 Max. 24A	6A/ch x3 Max. 18A
Max. load power/ Potencia de salida	240W (12V) / 480W (24V)	288W / 576W (12V/ 24V)	90W (5V), 216W (12V), 432W (24V)
Changing modes/ Cambios de modo	18 modes - 1 mode programmable/ 18 modos - 1 modo programable	39 modes/ modos	29 modes/ modos , 3 types/ tipos
DMX512 Standard/ Estándar	DMX512/ 1990	DMX512/ 1990	
DMX512 Sockets/ Conexiones	Green Terminal/ Terminal Verde	Standard XLR-3 connector, RJ45, Green Terminal/ Conector Estándar XLR-3, RJ45, Terminal Verde	Standard connector/ Conector Estándar
Working temperature/ Temp. trabajo	-30°C 65°C	-30°C 65°C	-30°C 65°C
Measures/ Medidas (mm)	L175 x W44 mm x H27 mm	L163 x W108 mm x H40 mm	L146 x W90 mm x H31 mm
Weight/ Peso	149 g	750 g	470 g

# Power repeater/ Módulo ampliación potencia

If the addition of the powers of the lamps to be governed with each aforementioned controller is bigger than the power that it supports, our signal repeaters can be used. This way a single controller can control as many lamps as the sum of the powers of the installed signal repeaters.

Cuando la suma de las potencias de los focos a gobernar con estos controladores es mayor que la que pueden soportar dichos controladores, existen los repetidores de la señal generada por los controladores. De esta manera un único controlador puede gobernar tantos focos como la suma de potencia de los repetidores de señal se instalen.

ONSTOCK

RGBW

LED



Reference/ Referencia	F6325345	F6324243
Type/ Tipo	RGBW	RGB
Input voltage/ Tensión entrada	DC 5V - DC 24V	DC 5V - DC 24V
Max. load current/ Corriente salida	5A/ch x4 Max. 20A	8A/ch x3 Max. 24A
Max. load power/ Potencia de salida	240W (12V)/480W (24V)	288W (12V)/ 576W (24V)
Working temperature/ Temp. trabajo	-30°C 65°C	-30°C 65°C
Measures/ Medidas (mm)	L175 x W44mm x H20 mm	L148 x W87 x H23
Weight/ Peso	141 g	380 g

# Power supply/ Fuente de alimentación

Reference/ Referencia	F6330115	F6330126	F6330137
Input voltage/ Tensión entrada	220V AC	110 - 220V AC	110 - 220V AC
Output voltage/ Tensión salida	24V DC		
Power/ Potencia	150W	350W	500W
Reference/ Referencia	F6330014	F6330025	F6330036
Input voltage/ Tensión entrada	220V AC	110 - 220V AC	110 - 220V AC
Output voltage/ Tensión salida	12V DC		
Power/ Potencia	150W	350W	500W

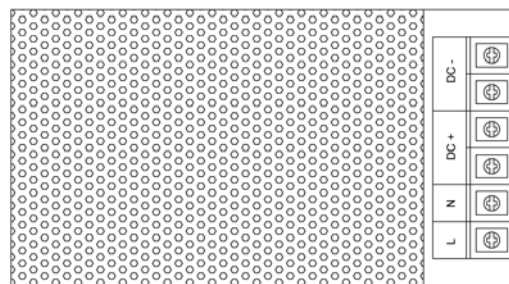

# Sample installation/ Ejemplo de instalación

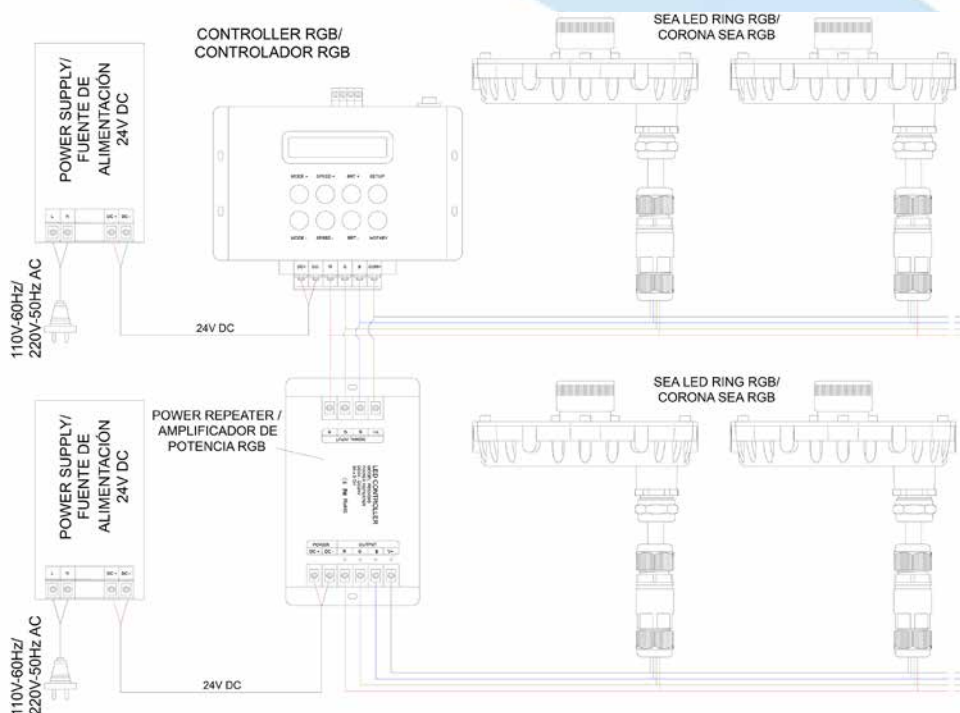



# Underwater solenoid/ Electroválvula sumergible

These underwater electric valves (IP68) are especially suited to controlling water jets in cybernetic fountains. The fact that they are underwater makes the fitter's work much easier as he can use them inside the architectural water feature and does not have to take them to a dry room.

Furthermore, Safe-Rain's RDI department is able to design any electric switchboard which controls these electric valves and, in this way, produce the desired water effect.

Estas electroválvulas sumergibles (IP68) son especialmente adecuadas para el gobierno de chorros de agua en fuentes cibernéticas. El hecho de que sean sumergibles facilita enormemente la labor del instalador, ya que puede usarlas dentro de la fuente ornamental y evita tener que llevarlas a un cuarto seco.

Además el departamento de I+D+i de Safe-Rain es capaz de diseñar cualquier cuadro eléctrico que gobierne dichas electroválvulas y conseguir, de este modo, el efecto acuático deseado.

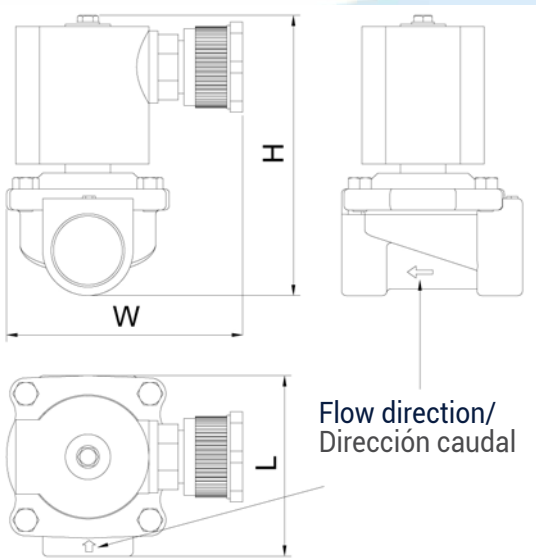

Reference/ Referencia	F7201045	F7201541
Port size/ Conexión BSP	G1" H-H / F-F	G1½" H-H / F-F
Tensión/ Voltage	24V DC	
Power/ Consumo	20W	
Working pressure/ Presión de trabajo	0-5 Atm.	
Max. working pressure/ Presión max. de trabajo	10 Atm.	
Max. working temperature/ Temp. max. fluido	60° C	
Type/ Tipo	Normally closed/ Normalmente cerrada (NC)	
Material/ Material	Stainless steel/ Acero inoxidable AISI-304	
Protection/ Protección	IP 68	
Length/ Largo (L)	81 mm	121 mm
Width/ Ancho (W)	111 mm	122 mm
Height/ Alto (H)	120 mm	150 mm
Weight/ Peso	1,2 kg	2,2 kg

## Head loss/ Perdida de carga (kg/cm<sup>2</sup>)

Reference/ Referencia	l/min	75	100	125	150	175	200
		m <sup>3</sup> /h	4,5	6,0	7,5	9,0	10,5
F7201045	Ø1"	0,30	0,45	0,55	0,83	1,07	-
F7201541	Ø1½"	0,20	0,25	0,35	0,48	0,69	0,94

# Anemometer/ Anemómetro

**W**ind can cause undesirable effects on a architectural fountain. That is why we have designed an anemometer for architectural fountains that performs three programmable actions depending on the wind speed. Thanks to our anemometer for architectural fountains you can schedule actions to take when the wind reaches an excessive speed.

**E**l viento puede provocar efectos no deseados en una fuente ornamental y por este motivo hemos diseñado un anemómetro para fuentes ornamentales que lleva a cabo tres acciones programables en función de la velocidad del viento. Gracias a nuestro anemómetro para fuentes ornamentales podrás programar las acciones a tomar cuando el viento alcance una velocidad excesiva.



Reference/ Referencia	Anemometer/ Anemómetro
F7323884	Anemometer Complete( control module+Cap)/ Anemómetro completo
F7323873	Anemometer control Module/ Módulo para control de Anemómetro
F7323838	Cap anemometer/ Veleta de Impulsos

# Water level controller/ Control de nivel de agua



**S**ystem that automatically controls the minimum and maximum water levels of architectural fountains with two electrodes, one for the minimum level and the other for the maximum level. When the minimum water level is reached, the solenoid valve connected to the sensor is opened. It closes automatically when the maximum level is reached.

The assembly includes the panel, the 1" 24V AC solenoid valve and electrodes (cable not included).

**S**istema que controla el nivel de agua mínimo y máximo de la fuente ornamental de forma automática, con dos electrodos, uno para el nivel mínimo y otro para el nivel máximo. Cuando el nivel de agua llega al mínimo, se acciona la electroválvula conectada a la sonda y se cierra automáticamente al llegar al nivel máximo.

El conjunto incluye cuadro, electroválvula de 1" a 24V AC y electrodos, (no se incluye el cable).



Reference/ Referencia	Water Level Controller/ Sonda de nivel
F 7311003	Water level control panel with solenoid valve and sensor / Cuadro de control de nivel con sonda y electroválvula

Further information at [www.saferain.com](http://www.saferain.com) | Más información en [www.saferain.com](http://www.saferain.com)

# Junction boxes/ Cajas de conexión

Underwater junctions are used to make completely safe underwater connections with a protection rating of IP X8.

Los empalmes subacuáticos se utilizan para hacer conexiones eléctricas sumergidas en el agua con total seguridad con un índice de protección IP X8.



Reference/ Referencia	F6402306	F6402407	F6402205	F6402508	F6402701	F6404916	F6404938
Model/ Modelo	2"						
Body material/ Material cuerpo	ABS				Brass/ Latón		
Cover material/ Material tapa	Methacrylate/ Metacrilato					Brass/ Latón	
Outlet No. and PG type/ N° de salidas y Tipo de PG	5 PG16	5 PG16	5 PG9	4 PG9 1 PG 16	5 PG9 2 PG-11	4 PG16 1 PG 21	4 PG16 1 PG 21
PG Material/ Material PG	Brass/ Latón	Plastic/ Plás- tico	Plastic/ Plás- tico	Plastic/ Plás- tico	Plastic/ Plás- tico	Brass/ Latón	Brass/ Latón
Measure/ Medida A (mm)	Ø128					Ø139	
Measure/ Medida B (mm)	64			82		60	
Weight/ Peso (kg)	0,5			1,6		2,0	

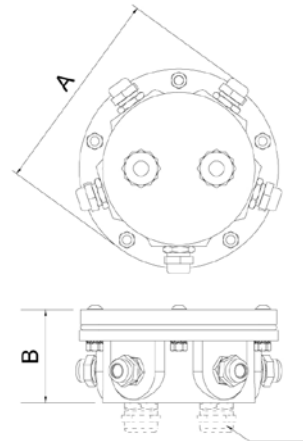

Just model/ Sólo modelo F6402701

Reference/ Referencia	F6411306	F6411317	F6411205	F6412307	F6412318	F6412206
Model/ Modelo	3"					
Body material/ Material cuerpo	Brass/ Latón					
Cover material/ Material tapa	Methacrylate/ Metacrilato			Brass/ Latón		
Outlet No. and PG type/ N° de salidas y Tipo de PG	9 PG16 3 PG 21	6 PG16 6 PG 21	12 PG 21	9 PG16 3 PG 21	6 PG16 6 PG 21	12 PG 21
PG Material/ Material PG	Brass/ Latón					
Measure/ Medida A (mm)	Ø252					
Measure/ Medida B (mm)	67					
Weight/ Peso (kg)	5,0			10,4		

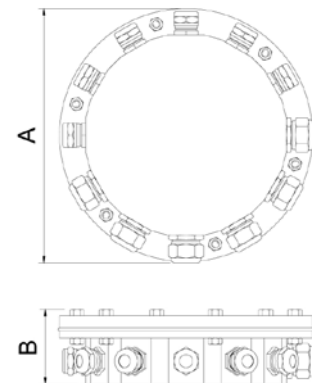

## Underwater junction/ Empalme subacuático

Reference/ Referencia	F6403634	F6403318
Model/ Modelo	Underwater junction/ Empalme subacuático	
Body material/ Material cuerpo	Stainless steel/ Acero inox. AISI304	
Cover material/ Material tapa	-	
Outlet No. and PG type/ N° de salidas y Tipo de PG	2 PG 21	2 PG16
PG Material/ Material PG	Brass/ Latón	
Measure/ Medida A (mm)	Ø27,7	Ø34,6
Measure/ Medida B (mm)	159	177
Weight/ Peso (kg)	0,26	0,31



PG	PG 9	PG 11	PG 16	PG 16	PG 21
Material/ Material	Plastic/ Plástico	Plastic/ Plástico	Plastic	Brass/ Latón	Brass/ Latón
Cable diam/ Diam cable (mm)	Ø4 to Ø8	Ø5 to Ø10	Ø10 to Ø14	Ø6 - Ø9 - Ø12	Ø11,7 - Ø15 - Ø18,6



# Wall bushing/ Pasamuros

**W**all bushings are installed during the construction work. The aim of the wall bushing is to allow cables to run safely from the external panel to the inside of the basin or fountain. Once inside the basin of the architectural water feature, each cable is connected to complement (light, solenoid valve, etc.) or to a junction box. We have defined the following models, depending on the number of electrical cables and their diameter.

**E**l pasamuros se empotra durante la obra civil. La finalidad del pasamuros es la de hacer llegar los cables desde el cuadro exterior hasta el interior del vaso o pileta de forma segura. Una vez dentro del vaso de la fuente ornamental cada cable se conecta a un receptor (foco, electroválvula, etc) o a su vez a una caja de conexiones. Dependiendo del número de mangueras eléctricas y de su diámetro hemos definido los siguientes modelos.



Model/ Modelo 1

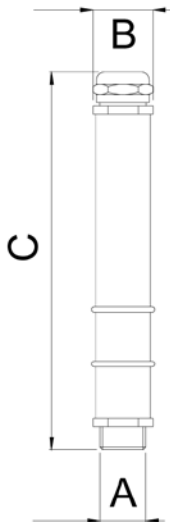

Model/ Modelo 2

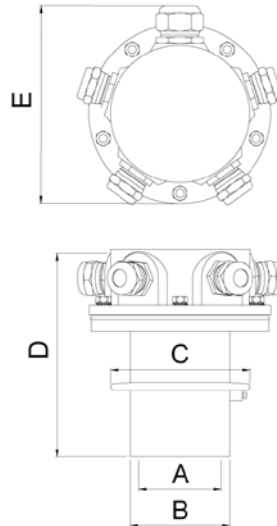

Model/ Modelo 3

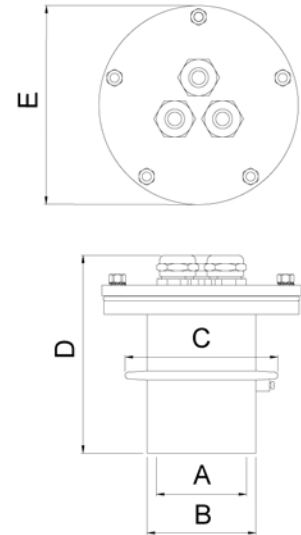

Reference/ Referencia	F6408303	F6408606	F6406931	F6414322	F6414333	F6414208	F6414219	F6405322	F6405614	F6415301
Model/ Modelo	1		2				3			
Material/ Material	Stainless steel/ Acero Inox. AISI 304		Brass/ Latón							
Outlet No. and PG type/ N° de salidas y Tipo de PG	1 PG16	1 PG 21	4 PG16 1 PG 21	9 PG16 3 PG 21	6 PG16 6 PG 21	12 PG 21	19 PG 21	3 PG16	1 PG 21	7 PG 21
PG Material/ Mate- rial PG	Brass/ Latón									
Measure/ Medida A (mm)	G ½" M		G 2" F/ H		G 3" F/ H			G 2" F/ H		G 3" F/ H
Measure/ Medida B (mm)	Ø27,5	Ø35	Ø72		Ø96			Ø72		Ø96
Measure/ Medida C (mm)	174	183	Ø102				Ø126			
Measure/ Medida D (mm)	-	-	150		186		206	128	133	163
Measure/ Medida E (mm)	-	-	Ø139		Ø252			Ø129		Ø252
Weight/ Peso (kg)	0,27	0,29	3		9,3		9,5	2,5		9,5

# Water pumps/ Bombas de agua

We know that the water pump is the heart of an architectural fountain. Speaking of water fountain pumps distributed by Safe-Rain means **reliability, durability, strength, efficiency, and excellent performance**. Our technical and sales teams undergo extensive training, and will advise you and guide you in the choice of the water pump best suited to the requirements of your architectural fountain project.

Sabemos que la bomba de agua es el corazón de una fuente ornamental. Hablar de las bombas de agua que distribuimos es hablar de **fiabilidad, resistencia, durabilidad, eficiencia e inmejorables prestaciones**. Nuestro equipo técnico y comercial dispone de una gran formación y te asesorará para guiarte en la elección de la bomba de agua que mejor se adapte a las necesidades de tu proyecto de fuente ornamental.



Certifications/ Certificaciones

IP68 CE UL



\* Measure with BSP thread adapter/ Cota con adaptador de rosca BSP

Measures/ Medidas

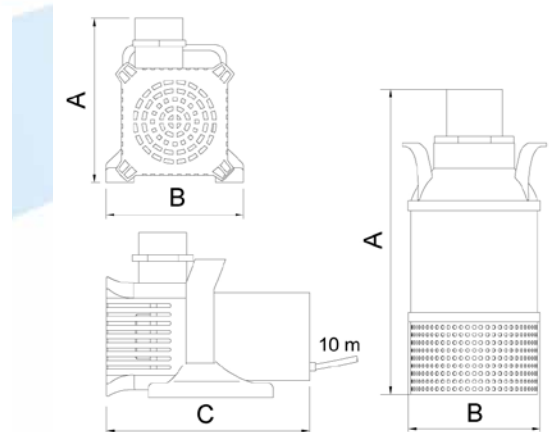
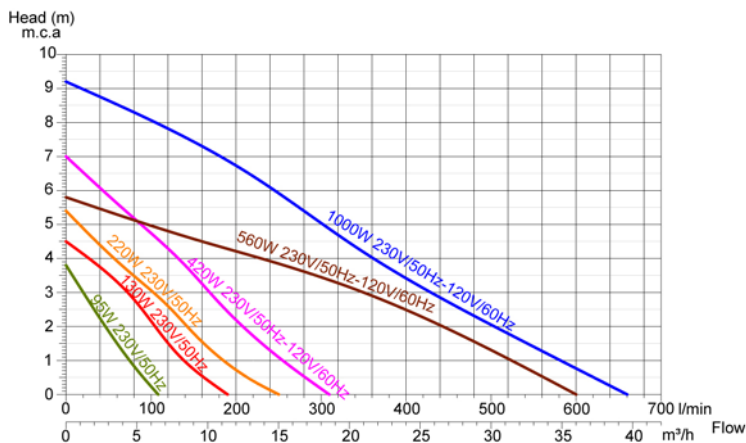

Reference/ Referencia	Power/ Potencia	Voltage/ Tensión	Pump outlet/ Conexión bomba		Max. flow/ Caudal max.	Max. pressure/ Presión max.	Measure/ Medida A	Measure/ Medida B	Measure/ Medida C	Weight/ Peso
	W	V/ Hz	BSP	NPT	l.p.m.	m.c.a.	mm	mm	mm	kg
F6524908	95	230/50	G 1½" M - F/ M - H		110	3,8	149	127	207	4,0
F6524403	130	230/50	G 1½" M - F/ M - H		190	4,5	171	146	249	4,9
F6524504	220	230/50	G 1½" M - F/ M - H		250	5,4	171	146	249	5,4
F6524605	420	230/50	G 1½" M - F/ M - H		310	7,0	195	146	249	6,7
F6526607	420	120/60	G 1½" M - F/ M - H		310	7,0	195	146	249	6,7
F6524706	560	230/50	G 4" F/H-Ø75	-	600	5,8	486	Ø197	-	9,8
F6526708	560	120/60	G 4" F/H-Ø75	-	600	5,8	486	Ø197	-	9,8
F6524807	1000	230/50	G 2½" M	G 2½" M	660	9,2	208/ *267	224	323	12,7
F6526809	1000	120/60		G 2½" M	660	9,2	208/ *267	224	323	12,7

Accesorios/  
Accesorios

# BESPOKE FOUNTAIN KITS/ KITS DE FUENTE A MEDIDA

**O**ur prefabricated fountain kits are developed on demand and on request from the customer to adapt to all of your needs. They include all mechanical and electrical equipment necessary to function and provide you the complete product, fully assembled and wired, and ready to go.

The installation of these fountain kits is as simple as unwrapping the product and plugging in the cables (plug & play).

**N**uestros kits de fuentes prefabricados son desarrollados bajo demanda y a petición del cliente para adaptarnos a todas tus necesidades. Incorporan todos los dispositivos mecánicos y eléctricos necesarios para funcionar y te entregamos el producto totalmente ensamblado y cableado, listo para funcionar.

La instalación de estos kits de fuentes es tan sencilla como desembalar el producto y enchufar los cables (plug & play).

**BESPOKE**  
A MEDIDA

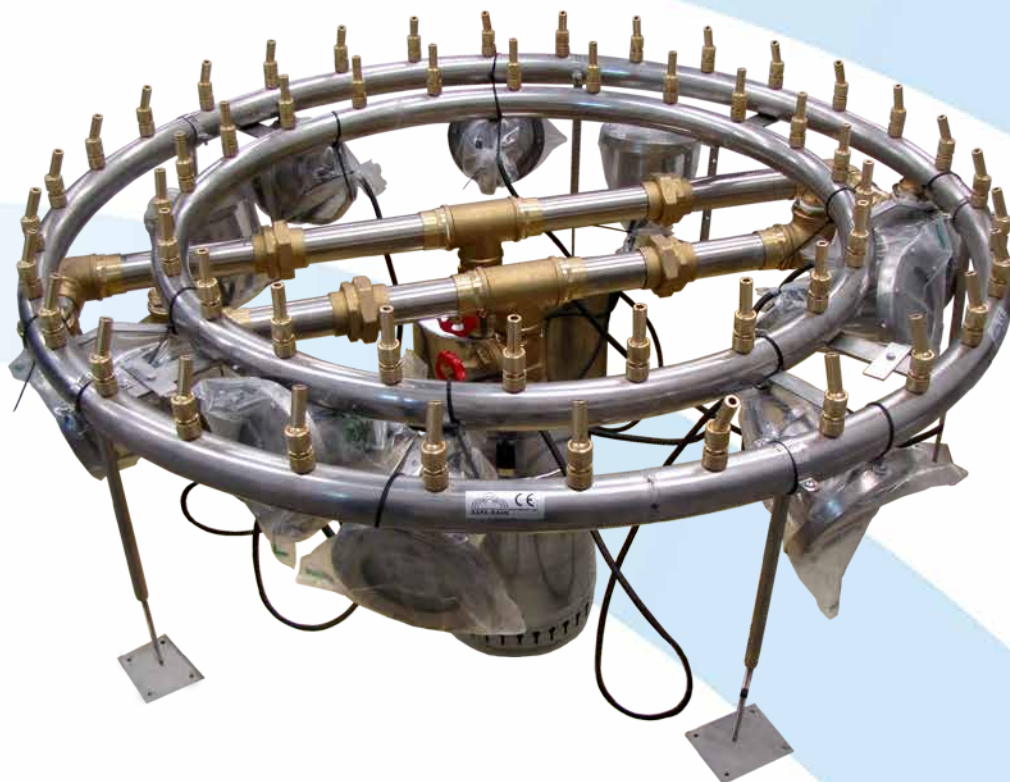

## KIT INCLUDES/ EL KIT INCLUYE

- **Nozzles**
- **Submersible lighting:** LED or Underwater lights
- Water pump(s)
- Spray ring(s)
- Accessories to complete the fountain's infrastructure: overflow, level control, anemometer, etc.
- **Boquillas**
- **Focos Sumergibles:** LED o Halógenos
- Bomba(s) de agua
- Colector(es)
- Accesorios para completar la infraestructura de la fuente: rebosadero, control de nivel, anemómetro ... etc.

Further information at [www.saferain.com](http://www.saferain.com) | Más información en [www.saferain.com](http://www.saferain.com)





ENT | EQUIPAMIENTO PARA FUENTES | MATÉRIELS POUR FONTAINES | EQUIPAMENTO DE



Site: [www.saferain.com](http://www.saferain.com) E-Mail: [info@saferain.com](mailto:info@saferain.com)  
Telf: (+34) 925 531 480 Fax: (+34) 925 530 257  
Calle Cobre nº 6 - 45520. Villaluenga de la Sagra (Toledo) - Spain.